



Operating Manual
ULTIMA® X5000
Gas Monitor



Order No.: 10177361/09
Print Spec: 10000005389 (EO)
CR: 800000067087

⚠ WARNING!

These instructions must be provided to users before use of the product and retained for ready reference by the user. Read this manual carefully before using or maintaining the device. The device will perform as designed only if it is used and maintained in accordance with the manufacturer's instructions. Otherwise, it could fail to perform as designed, and persons who rely on this device could sustain serious injury or death.

The warranties made by MSA with respect to the product are voided if the product is not installed and used in accordance with the instructions in this manual. Please protect yourself and your employees by following the instructions.

Please read and observe the WARNINGS and CAUTIONS inside. For additional information relative to use or repair, call 1-800-MSA-2222 during regular working hours.

For countries of Russian Federation, Republic of Kazakhstan and Republic of Belarus, the gas detector will be delivered with a passport document that includes valid approval information. On the CD with manual instruction attached to the gas detector the user will find the documents "Type Description" and "Test Method" - appendixes to Pattern Approval Certificate of Measuring instrument, valid in the countries of use.

The Declaration of Conformity can be found under the following link: <https://MSAsafety.com/DoC>.

MSA is a registered trademark of MSA Technology, LLC in the US, Europe and other Countries. For all other trademarks visit <https://us.msasafety.com/Trademarks>.

This product incorporates Bluetooth® wireless technology. The Bluetooth word mark and logos are registered trademarks owned by Bluetooth SIG, Inc., and any use of such marks by MSA is under license. Other trademarks and trade names are those of their respective owners.

This device complies with part 15 of the FCC Rules. Operation is subject to the following two conditions: (1) This device may not cause harmful interference, and (2) this device must accept any interference received, including interference that may cause undesired operation.

You are cautioned that changes or modifications not expressly approved by the party responsible for compliance could void the user's authority to operate the equipment.

English:

This device complies with RSS-210 of the Industry Canada Rules. Operation is subject to the following two conditions: (1) This device may not cause harmful interference, and (2) this device must accept any interference received, including interference that may cause undesired operation.

French:

Ce dispositif est conforme à la norme CNR-210 d'Industrie Canada applicable aux appareils radio exempts de licence. Son fonctionnement est sujet aux deux conditions suivantes: (1) le dispositif ne doit pas produire de brouillage préjudiciable, et (2) ce dispositif doit accepter tout brouillage reçu, y compris un brouillage susceptible de provoquer un fonctionnement indésirable.



The Safety Company

1000 Cranberry Woods Drive
Cranberry Township, PA 16066
USA
Phone 1-800-MSA-2222
Fax 1-800-967-0398

For your local MSA contacts, please go to our website www.MSAsafety.com

Contents

1	Safety Regulations	4
1.1	Correct Use	4
1.2	Product Warranty	5
2	Description	7
2.1	Display	7
2.2	Operator Interface	7
2.3	Bluetooth® Wireless Technology	8
2.4	Dual Sensing	8
2.5	Retrofit Installations	8
2.6	XCell Sensors Optimized for Fixed Gas Applications	8
2.7	TruCal® Sensing Technology for CO and H2S Electrochemical Sensors	8
2.8	SafeSwap®	9
2.9	Housing	9
2.10	Component Overview	10
2.11	Label Overview	10
3	Installation	11
3.1	Installation Warnings - Read Before Installation	11
3.2	Reviewing Shipment and Identifying Product Model	12
3.3	Product Installation Check List	12
3.4	Mounting	13
3.5	Installing a Remote Sensor Junction Box	19
3.6	Electrical Power Connections	20
4	Operation	32
4.1	Startup	32
4.2	Settings	33
4.3	Status Menu	54
5	Calibration	54
5.1	Calibration Equipment	55
5.2	Calibration Frequency	57
5.3	Calibration Frequency for XCell Sensors with TruCal (H2S & CO only)	57
5.4	Calibration Types: Zero vs. Span	58
5.5	How to Zero Calibrate XCell Sensors	58
5.6	How to Calibrate XCell Sensors	59
5.7	How to Calibrate an Oxygen XCell Sensor	60
5.8	How to Calibrate an XIR PLUS Sensor	61
5.9	XCell Catalytic Bead LOC Over Range	61
5.10	Calibration Confirmation and As Found/As Left Values	61
6	Maintenance	62
6.1	ULTIMA XIR PLUS Cleaning Procedure	62
6.2	Replacing an XCell Sensor	63
6.3	Clearing a Blockage	64
6.4	Troubleshooting	65
7	Ordering Information	71
7.1	Replacement Parts	71
8	Appendix: Specifications	73
9	Appendix: Calibration Guide for Additional Gases	76
10	Appendix: General Certification Information	82
11	Appendix: HART Specific Information	85
12	Appendix: Modbus RTU Protocol Operation	86
12.1	Baud Rate	86
12.2	Data Format	87

1 Safety Regulations

1.1 Correct Use

The ULTIMA X5000 Gas Monitor, hereafter also called device, is a gas monitor for measuring toxic and combustible gases as well as oxygen. Using sensors, the device tests the ambient air and triggers the alarm as soon as the gas exceeds a specific concentration level.

WARNING!

Read this manual carefully. The device will perform as designed only if it is used, installed, and maintained in accordance with the manufacturer's instructions. Otherwise, it could fail to perform as designed and persons who rely on this device for their safety could sustain serious personal injury or loss of life.

WARNING!

Do not use silicone-type lubricants in assembling the device and do not allow silicone vapors to be drawn into the flow system while in operation. Silicone can desensitize the combustible gas sensor, thereby giving erroneously low readings.

Use only genuine MSA replacement parts when performing any maintenance procedures provided in this manual. Failure to do so may seriously impair sensor and gas monitoring performance, alter flameproof/explosion proof characteristics or void agency approvals.

Failure to follow this warning can result in serious personal injury or death.

WARNING!

As with all gas monitors of this type, high levels of, or long exposure to, certain compounds in the tested atmosphere could contaminate the sensors. In atmospheres where an X5000 Gas Monitor may be exposed to such materials, calibration must be performed frequently for dependable operation and to confirm that display indications are accurate.

These effects include, but are not limited to:

- Passive MOS sensors may be adversely affected by prolonged exposure to certain substances. Loss of sensitivity or corrosion may be gradual if such agents are present in low concentrations or it may be rapid at high concentrations.

Examples of these substances are as follows:

- Halides: compounds containing fluorine, chlorine, bromine and iodine
- Heavy metals, e.g. tetraethyl lead
- Caustic and Acidic liquids and vapors
- Glycol
- The H₂S Digital Sensor may be adversely affected by the following substances:
 - Alcohols (methanol, ethanol, isopropanol)
 - Nitrogen dioxide (NO₂)
 - Chlorine (Cl₂)
 - Paint solvents (acetone, turpentine, toluene, mineral spirits, etc.)
- The CO Digital Sensor may be adversely affected by the following substances:
 - Alcohols (methanol, ethanol, isopropanol)
 - Paint solvents (acetone, turpentine, toluene, mineral spirits, etc.)
- The O₂ Digital Sensor may be adversely affected by the following substances:

1 Safety Regulations

- Long term exposure to low levels of Acetylene
- Paint solvents (acetone, turpentine, toluene, mineral spirits, etc.) in high concentrations larger than 1000 ppm or prolonged exposure to lower concentrations
- Prolonged exposure of SO₂ sensors to ammonia (NH₃) will result in longer response times and SO₂ readings that are lower than the actual gas concentration present.
- Prolonged exposure of the H₂S Digital Sensor to humidity levels of 5% RH or lower will result in gas measurement readings of H₂S that are greater than the actual gas concentration present.
- It is not recommended to expose the O₂, H₂S and CO Digital Sensors to environments containing oxygen levels above 30% (v/v) or below 5% (v/v). The O₂ sensor will operate at concentrations below 5% (v/v) but not for prolonged periods of time.

Failure to follow these warnings can result in serious personal injury or death.

This device complies with Part 15 of the FCC Rules. Operation is subject to the following two conditions:

- device may not cause harmful interference, and
- device must accept any interference received, including interference that may cause undesired operation.



This equipment has been tested and found to comply with the limits for a Class A digital device, pursuant to Part 15 of the FCC Rules. These limits are designed to provide reasonable protection against harmful interference when the equipment is operated in a commercial environment. This equipment generates, uses, and can radiate radio frequency energy and, if not installed and used in accordance with the instruction manual, may cause harmful interference to radio communications. Operation of this equipment in a residential area is likely to cause harmful interference in which case the user will be required to correct the interference at the user's expense.

NOTICE

This is a Class A product in accordance with CISPR 22. In a domestic environment, this product may cause radio interference, in which case the user may be required to take adequate measures.

NOTICE

The XCell[®] sensor refers to the sensor portion of the Digital Sensor throughout this manual.

FCC Warning Statements

Changes or modifications not expressly approved by the manufacturer could void the user's authority to operate the equipment.

Industry Canada (IC) Warning Statements

The installer of this radio equipment must ensure that the antenna is located or pointed such that it does not emit RF field in excess of Health Canada limits for the general population; consult Safety Code 6, obtainable from Health Canada's website www.hc-sc.gc.ca.

1.2 Product Warranty

ITEM	WARRANTY PERIOD
ULTIMA X5000 Gas Monitor	MSA warrants that this product will be free from mechanical defects and faulty workmanship for the period specified in this table for each component, provided it is maintained and used in accordance with MSA's instructions and/or recommendations. Guarantee shall not exceed the indicated warranty period plus six months from the date of manufacture.
Main Transmitter Housing and PCBA	2 years from date of shipment.
XCell Sensors	3 years from date of shipment.

ITEM	WARRANTY PERIOD
XIR PLUS	5 years on electronics. 10 years on IR source bulb.
Electrochemical Sensors	1 year from date of shipment

This warranty does not cover filters, fuses, etc. Certain other accessories not specifically listed here may have different warranty periods. This warranty is valid only if the product is maintained and used in accordance with Seller's instructions and/or recommendations. The Seller shall be released from all obligations under this warranty in the event repairs or modifications are made by persons other than its own or authorized service personnel or if the warranty claim results from physical abuse or misuse of the product. No agent, employee or representative of the Seller has any authority to bind the Seller to any affirmation, representation or warranty concerning this product. Seller makes no warranty concerning components or accessories not manufactured by the Seller, but will pass on to the Purchaser all warranties of manufacturers of such components.

THIS WARRANTY IS IN LIEU OF ALL OTHER WARRANTIES, EXPRESSED, IMPLIED OR STATUTORY, AND IS STRICTLY LIMITED TO THE TERMS HEREOF. SELLER SPECIFICALLY DISCLAIMS ANY WARRANTY OF MERCHANTABILITY OR OF FITNESS FOR A PARTICULAR PURPOSE.

Exclusive Remedy

It is expressly agreed that Purchaser's sole and exclusive remedy for breach of the above warranty, for any tortious conduct of Seller, or for any other cause of action, shall be the replacement at Seller's option, of any equipment or parts thereof, which after examination by Seller is proven to be defective. Replacement equipment and/or parts will be provided at no cost to Purchaser, F.O.B. Seller's Plant. Failure of Seller to successfully replace any nonconforming equipment or parts shall not cause the remedy established hereby to fail of its essential purpose.

Exclusion of Consequential Damage

Purchaser specifically understands and agrees that under no circumstances will seller be liable to purchaser for economic, special, incidental or consequential damages or losses of any kind whatsoever, including but not limited to, loss of anticipated profits and any other loss caused by reason of non-operation of the goods. This exclusion is applicable to claims for breach of warranty, tortious conduct or any other cause of action against seller.

2 Description

2.1 Display

The ULTIMA X5000 utilizes an Organic LED (OLED) display which is capable of being seen from a distance of up to 50 ft (15 m) depending on conditions. The OLED display provides clear and crisp information in a variety of languages. The gas reading gauge, which wraps around the live reading area, mimics the reading as a percent of full scale and is also used as a progress bar during operations which require a countdown.

NOTE: Upon power up, ensure all visual indicators are functioning as shown in [Figure 1](#) . All visual indicators light up at the same time momentarily as part of the startup sequence. Visual indicator functionality may be tested by restarting the S5000.

Figure 1 OLED Display

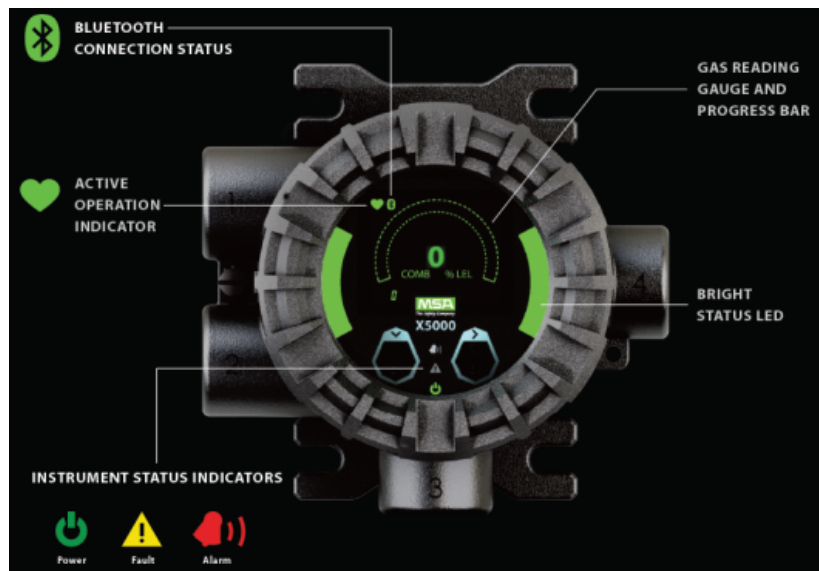

In addition to the OLED display, the ULTIMA X5000 also employs green, yellow and red LEDs on the side and lower middle of its face. These are used to signal normal operating conditions, fault conditions and alarm conditions.

The ULTIMA X5000 will go into “Eco-Mode” after 3 minutes of no interaction and if not in an alarm condition. While in Eco-Mode, the main display will power down and the status LED's will remain illuminated to determine that the device is not in an alarm condition. The OLED display can be powered up by touching either of the two EZ touch buttons on the front display.

2.2 Operator Interface

The ULTIMA X5000 does not require any tools or third party devices to change settings, reset alarms or perform any maintenance feature. The EZ touch buttons work through the glass and do not require opening the explosion proof enclosure. The EZ touch buttons work with bare fingers or with gloved hands, so long as the gloves are not black. The down arrow is used for scrolling, while the right arrow is used for selecting options. See section 4 for more information on navigating the menu with the EZ touch buttons.



Figure 2 ULTIMA X5000 Interface

2.3 Bluetooth® Wireless Technology

The ULTIMA X5000 can be ordered with Bluetooth communication. Using the X/S Connect App on an appropriate smart phone or tablet, you are able to interface with the ULTIMA X5000 in a larger and more user friendly setting. Connecting via Bluetooth enables communication with transmitter up to 70 feet (21 m) away.

WARNING!

Bluetooth operation is dependent upon signal availability of the wireless service(s) necessary to maintain the communication link. Loss of wireless signal will prevent communication of alarms and other information to linked devices. Take appropriate precautions in the event a loss of wireless signal occurs.

Failure to follow this warning can result in serious personal injury or death.



If the device was not ordered with Bluetooth it cannot be upgraded.

If ordered with Bluetooth, the device will be shipped with Bluetooth enabled. See [4 Operation](#) for instructions on disabling Bluetooth.

The ULTIMA X5000 and user provided communication device will need to be paired. This requires both devices to be in range and for a pairing sequence inputting a 6 digit pairing code. The instructions will be displayed on both the ULTIMA X5000 and communication device.



There are communication devices capable of being used in classified areas. Please contact your MSA representative for additional information.

2.4 Dual Sensing

The ULTIMA X5000 is capable of communicating with and displaying information for two sensors at a time. There are no restrictions to the type of sensors connected to the device.

The ULTIMA X5000 Gas Monitor generates two discrete analog outputs; one for each sensor connected to the transmitter. The analog output associated with Sensor 1 also has the digital HART (Highway Addressable Remote Transducer) communication superimposed on the analog signal. If two sensors are connected, the digital HART communication carries information for both sensors.

2.5 Retrofit Installations

The ULTIMA X5000 has the conduit entries located in the exact same orientation and distance from the wall and the mounting holes for attaching to a wall are identical to the Ultima X.

2.6 XCell Sensors Optimized for Fixed Gas Applications

XCell toxic and combustible cat bead sensors are developed and manufactured by MSA. Now optimized for fixed gas applications, the XCell sensor platform is available in the ULTIMA X5000 and provides multiple benefits, including a standard 3-year warranty on all XCell sensors.

One important optimization for fixed gas was incorporating the GM catalytic bead into the XCell sensor.

The XCell Oxygen sensor does not use lead, but rather a non-consuming reaction chemistry. The XCell Oxygen sensor is expected to last well over 3-years and can be safely stored on the shelf for at least 1 year without sensor performance degradation. Changes in barometric pressure across the range of 86 kPa 108 kPa have a negligible effect on the operation of the sensor.

2.7 TruCal® Sensing Technology for CO and H₂S Electrochemical Sensors

Using patented pulse check technology and proprietary Adaptive Environmental Compensation (AEC) algorithms, all XCell sensors with TruCal verify operation by actively adjusting the sensor output for changes in sensitivity. Some XCell sensors

2 Description

with TruCal also include Diffusion Supervision, which monitors the sensor inlet for obstructions that could prevent gas from reaching the sensor.

Every six hours, an electrical pulse stimulates the XCell sensor similar to having actual calibration gas applied, providing a snapshot of the sensor's sensitivity at the time of the pulse. Using this sensitivity snapshot, the sensor can diagnose sensor failures like electrode poisoning, electrolyte leaking, or electrical connectivity issues.

AEC uses the sensitivity snapshots provided by the pulse check to adjust sensor output, compensating for environmental impacts on sensor accuracy. If the AEC adjustment is greater than expected based on typical environmental impact variations, the transmitter LED's will slowly flash GREEN, alerting users that the sensor should be calibrated to reset the AEC cycle. Users can also enable a Calibration Alert function that will send a milli-amp signal on the analog output to the control room. The result is a sensor that actively self-monitors for operation and accuracy, with far fewer manual calibrations.

Diffusion supervision actively monitors the sensor inlet for obstructions. If an obstruction is detected, the sensor will go into a fault mode to alert users and the control room that it is not seeing gas due to an obstruction. Objects residing directly on or in the sensor inlet that result in a significant impact to the gas path are very likely to be detected by Diffusion Supervision. Examples include paint, tape, water, and dirt. Small amounts of these materials can be visible on the inlet while not impacting the gas path enough to trigger a Diffusion Supervision Fault. A fault signal will only be sent out when the system determines that the amount of material that has accumulated on or inside the sensor inlet is negatively affecting the gas path.

Actual TruCal sensor performance will depend on the application, background gas exposure, and environment. To validate XCell sensors with TruCal, it is recommended that users follow their regular calibration cycle and record the "as found" and "as left" values. This data can be used to extend the time between calibrations depending on the required specification of the application.

2.8 SafeSwap®

The ULTIMA X5000 comes with patented SafeSwap technology, which allows users to change or replace XCell sensors without needing to power down the instrument. For added convenience, the ULTIMA X5000 comes with Swap Delay enabled by default; a feature that gives users a 2 minute window to change sensors without triggering a fault condition. For more information on SafeSwap and Swap Delay, see [4.2.1 Instrument Settings](#).

WARNING!

- As part of the product certification, it was verified that optional communication functions of this gas detection instrument while operating at the maximum transaction rate do not adversely affect the gas detection operation and functions of the instrument. The product certification, however, does not include or imply approval of the SafeSwap feature, communications protocol or functions provided by the software of this instrument or of the communications apparatus and software connected to this instrument.
- Follow the warnings below when removing or replacing sensors. Reference [2.10 Component Overview](#) for component overview.
 - Never remove or replace a sensor body assembly or an Ultima XIR Plus while under power or when explosive hazards are present.
 - Confirm that the area is free of explosive hazards before removing or replacing an XCell Sensor under power.
 - To remove an XCell Sensor, unscrew XCell Sensor three full turns, wait 10 seconds, and then remove the XCell Sensor completely.

Failure to follow this warning can result in serious personal injury or death.

2.9 Housing

The ULTIMA X5000 comes in 316 Stainless Steel for the highest corrosion resistance. Both ¾" NPT and M25 conduit entries are available. To attach a sensor to an M25 housing, an M25 adapter is required and will be included with the shipment. An integral surface mount bracket can be used to mount directly into the wall surface or used with a U-Bolt for mounting to a 2" pipe. Custom tags are available and easily attach to an integral ring.

2.10 Component Overview

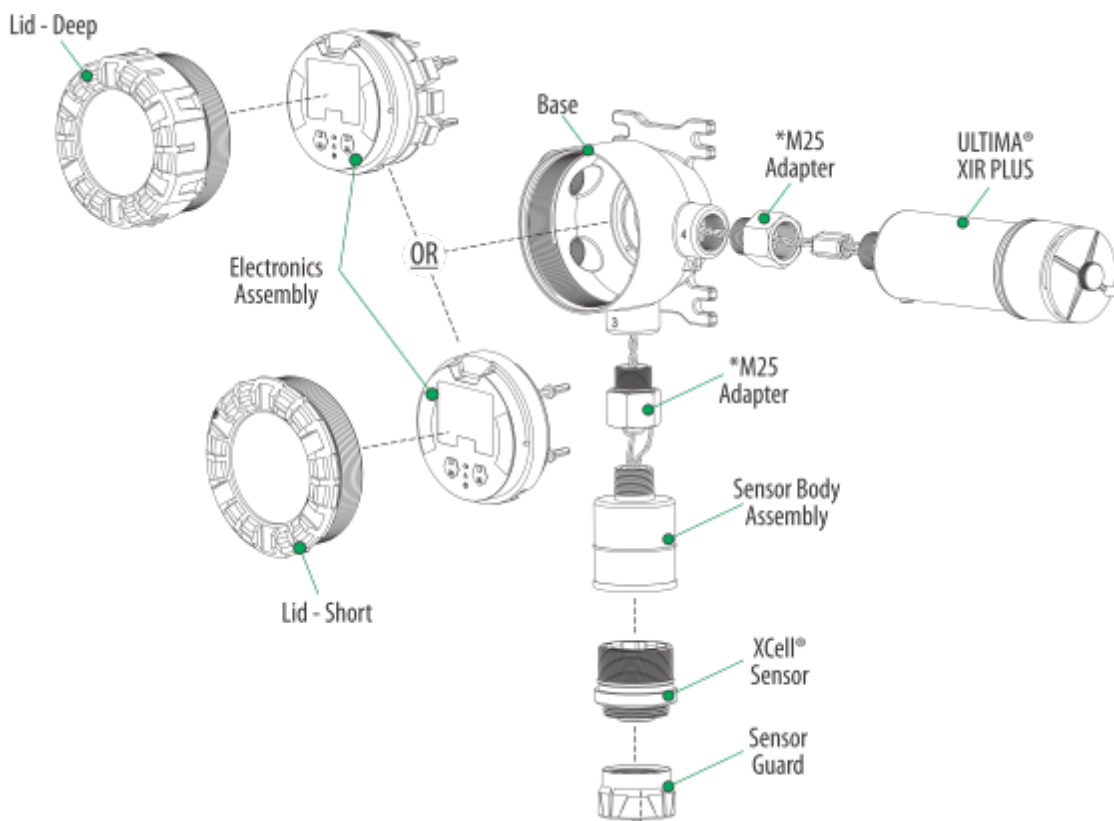

Figure 3 Component Overview

* Only used with M25 bases

2.11 Label Overview

Serial number is located where shown (highlighted in green). Actual number of digits may be different.

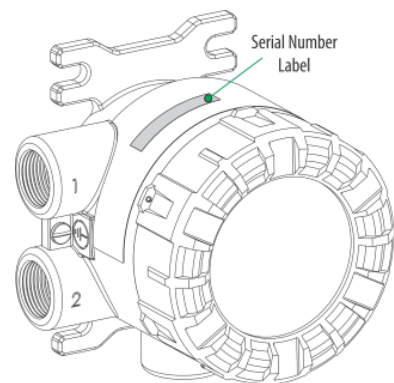

Figure 4 Serial Number Label

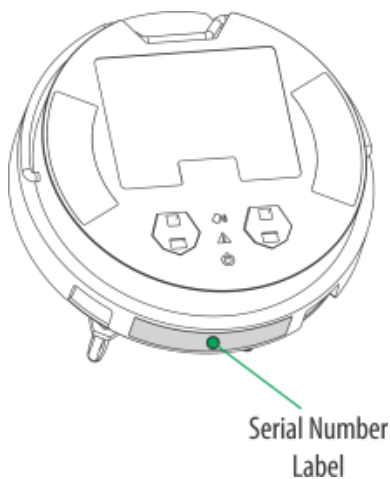

Figure 5 Board Stack - Position of Label

3 Installation

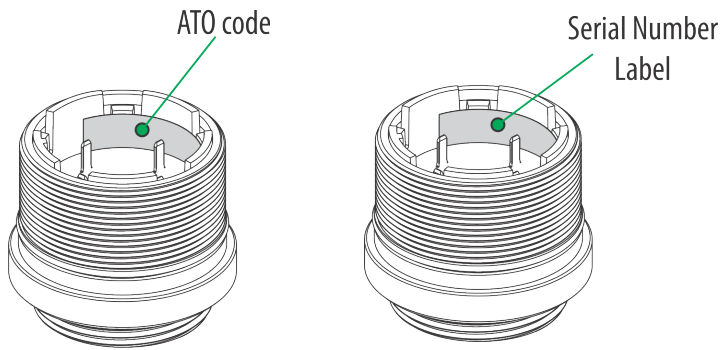

Figure 6 Digital Sensor - Position of Labels

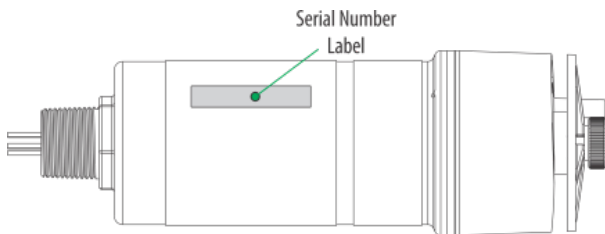

Figure 7 XIR Plus - Position of Labels

3 Installation

3.1 Installation Warnings - Read Before Installation

WARNING!

- Refer to manual addendum (P/N 10182779) for certification information and additional safety information before installation and operation.
- When utilizing the P+F Wireless HART Bullet accessory, read and understand the quick start guides (P/N 10218978 and 10218979) and P+F Wireless HART Bullet instruction manual (WHA-BLT-F9D0-N-A0-*) before installing and using. The P+F Wireless HART Bullet shall be installed as close to the X5000 transmitter, junction box or JB5000 as possible.
- Some digital sensors are provided in a fritless sensor housing. The fritless sensor housing is labeled as Div 2 or Zone 2 and is approved for Div 2 or Zone 2 installations only. The protection method is Non-incendive or Type n respectively. Ensure all components are approved for the wiring method being used and in accordance with the National Electrical Code of the country of use, any applicable local regulations, this manual and the addendum to the manual.
- As part of the product certification, it was verified that optional communication functions of this gas detection instrument while operating at the maximum transaction rate do not adversely affect the gas detection operation and functions of the instrument. The product certification, however, does not include or imply approval of the SafeSwap feature, communications protocol or functions provided by the software of this instrument or of the communications apparatus and software connected to this instrument.
- Follow the warnings below when removing or replacing sensors. Reference [Figure 3](#) for component overview.
 - Never remove or replace a sensor body assembly or an Ultima XIR PLUS while under power or when explosive hazards are present.
 - Confirm that the area is free of explosive hazards before removing or replacing an XCell Sensor under power.
 - To remove an XCell Sensor, unscrew XCell Sensor three full turns, wait 10 seconds, and then remove the XCell Sensor completely.
- Plug all unused conduit entries with a suitably certified blanking/stopping plug.
- Do not paint the device. Avoid painting in areas where the ULTIMA X5000 and remote sensor junction box are located. If painting is required in an area where an ULTIMA X5000 or remote sensor has been installed, exercise

caution to ensure paint is not deposited on the sensor inlet fitting. Paint solvents can also cause an alarm condition to occur or potentially poison electrochemical sensors.

- Protect the device from extreme vibration.
- Do not mount the sensing head in direct sunlight without a sunshield (P/N 10180254).
- The ULTIMA XIR PLUS Sensor contains no user- or field-serviceable parts and must be returned to the factory for repair. Any attempt to open the sensor will damage the unit and void the warranty.
- If the HCN sensor is exposed to continuous levels of HCN gas, this can result in erroneously low gas readings. This can occur in as little as 30 minutes of exposure. Do not operate in the presence of continuous low level background HCN gas. Use latching alarms to avoid an erroneous alarm clearance.
- Sensor sensitivity will recover over the course of several hours once HCN gas is removed. Use an independent instrument to confirm the absence of HCN gas and allow the sensor to return to zero prior to restarting operations.
- Use of some accessories are not covered under the performance approval. Contact MSA for details.

Failure to follow this warning can result in serious personal injury or death.

NOTICE

When installing the XIR PLUS sensor, under no circumstances should a pry-bar be applied to the two legs that support the unit's reflectors during installation or removal of the sensor. Applying force to the legs can permanently damage the XIR PLUS sensor.

3.2 Reviewing Shipment and Identifying Product Model

To determine your sensor type and options, check the shipping carton.



Figure 8 Shipping Label

The device is not shipped with the sensors attached to the housing. The XIR PLUS is a one piece sensor, but all other sensors are comprised of two parts; the Sensor Body Assembly and the XCell Sensor. Check the sensor details before attaching to the device housing to ensure that the correct sensor type is being installed. The sensor details are listed on the inside of the XCell Sensor. Unscrew the XCell Sensor from the Sensor Body Assembly and check the label on the inside for gas type, range, replacement ATO configuration, serial number, and firmware revision number.

3.3 Product Installation Check List

Before Installation

- Review national electrical codes
- Review local procedural and building codes
- Determine optimum transmitter placement
- Determine wire requirements
- Determine mounting hardware requirements
- Review approvals and ensure suitability for installation

Mounting

3 Installation

- Attach appropriate sensor to housing or junction box (see [3.4.3 Sensor Orientation](#) for proper sensor orientation)
- Mount transmitter or junction box using appropriate mounting hardware
- Confirm free air flow around the sensor

3.4 Mounting

WARNING!

Refer to manual addendum (P/N 10182779) for Certification Information before installation.

Some toxic gases are provided in a fritless sensor housing. The fritless sensor housing is labeled as Div 2 or Zone 2 and is approved for Div 2 or Zone 2 installations only. The protection method is Nonincendive or Type n respectively. Ensure all components are approved for the wiring method being used and in accordance with the National Electrical Code of the country of use, any applicable local regulations, this manual and the addendum to the manual.

Failure to follow this warning can result in serious personal injury or death.

3.4.1 Sensor Mounting Location

The best location for the transmitter and the sensor may not be the same location. Sensors should be placed in a location where a gas leak is most likely to be detected. When the best sensor placement would not allow the transmitter display to be easily viewed or accessed, a remote junction box can be used to mount the sensor remotely from the transmitter, allowing both to be installed in the optimum location.

Two main factors should be considered when choosing a sensor location. The first is the density of the target gas relative to the air. Gases, such as propane, that are heavier than air should be placed near ground level while gases that are lighter than air should be placed above potential leak sources.

Optimum sensor placement will depend on the surrounding processing equipment, such as pipes, valves, or turbines. MSA offers a fire and gas mapping service that systematically evaluates potential sources of leaks and recommends detector quantity and placement to create the most effective detection system.

3.4.2 Transmitter Mounting Location

The transmitter display should be mounted so that the screen is visible and easily accessed after installation. The electronics assembly inside the metal enclosure can be repositioned in any of the four self-aligning interior holes to ensure the display is properly oriented and to provide maximum flexibility for using conduit entries.

3.4.3 Sensor Orientation

WARNING!

Mount the XIR PLUS with the sensor inlet fitting extended horizontally from the main enclosure ([Figure 9](#)) to prevent the build-up of particulate or liquid matter on the monitor's optical surfaces.

Mount the digital sensor with the sensor inlet fitting ([Figure 10](#)) pointed downward; otherwise, the inlet may become clogged with particulate matter or liquids.

Failure to follow this warning can result in serious personal injury or death.

Sensor orientation will depend on the sensor type. If mounting an ULTIMA XIR PLUS sensor, whether locally on the transmitter or via remote junction box, the sensor should be mounted horizontally. If the ULTIMA XIR PLUS sensor is not mounted horizontally, the sensor will be prone to more frequent beam blocking issues due to accumulated dust and condensation on the surface of the ULTIMA XIR PLUS sensor. [Figure 9](#) shows the correct and incorrect mounting orientations for the ULTIMA XIR PLUS.

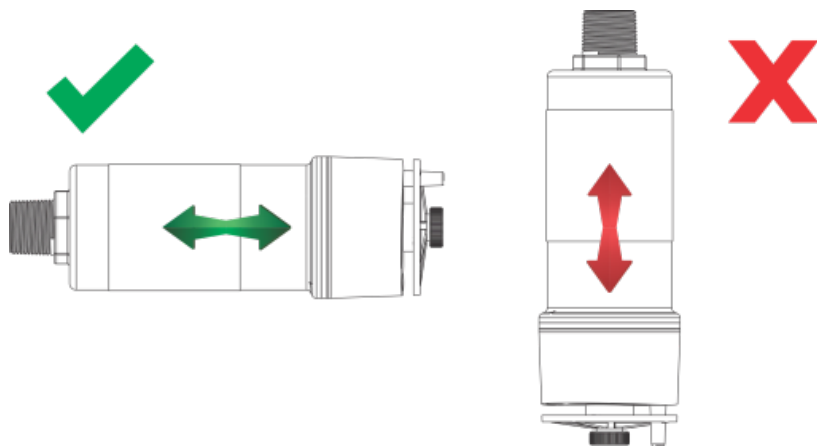

Figure 9 Correct and Incorrect Mounting Orientations for ULTIMA XIR PLUS Sensor

All other sensors including electrochemical, combustible catalytic bead, and oxygen sensors should be mounted vertically, with the gas inlet pointed downward. If the sensor is not mounted with the gas inlet facing down, it is more likely to become clogged with particulate matter or liquids. Figure 10 shows the correct and incorrect mounting orientation for digital sensors.

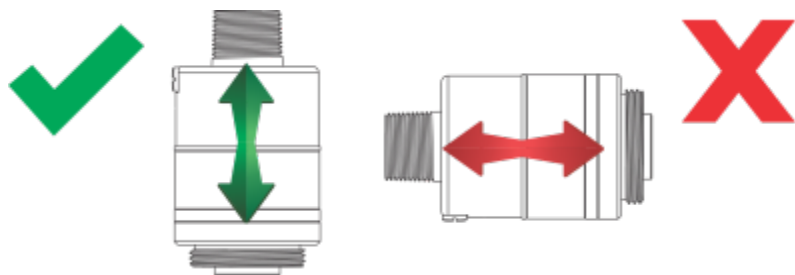

Figure 10 Correct and Incorrect Mounting Orientation for Digital Sensors

3.4.4 Connecting Sensor to Transmitter Housing or Remote Junction Box

Sensors are not shipped attached to the main enclosure or junction box. All sensor modules interface with the transmitter via a digital four-terminal connection. Up to two sensors can be connected to a single transmitter, with each sensor getting a dedicated analog (4-20 mA) output.

Consider the sensor dimensions when choosing a mounting location for the transmitter or junction box.

To connect the sensor:

1. Loosen the set screw located on the lid using a 1.5 mm Allen wrench.
2. Turn the transmitter or junction box lid counterclockwise to remove
3. Pull on the metal bail to remove the board stack and expose wiring connections.
4. Route the cable from the sensor through a conduit entry hole in the enclosure so that the sensor is oriented in the correct position (see 3.4.3 Sensor Orientation for details).

(Repeat to attach a second sensor to the ULTIMA X5000 transmitter).

5. Connect the sensor to the "Sensor 1" position on the electronics assembly.
 - a. If using a second sensor, connect it to the "Sensor 2" position.

NOTICE

If only using one sensor, and it is connected to "Sensor 2" position, the ULTIMA X5000 will enter *Sensor Missing* fault. See Disable Sensor in 4.2.2 Sensor Settings for details on how to clear this fault.

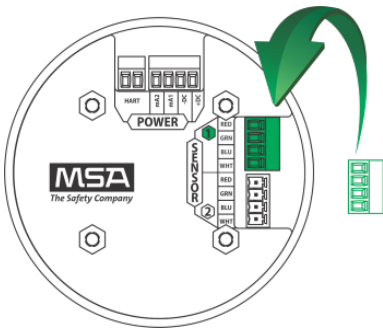

Figure 11 Connecting Sensor to the Stack

NOTE: Sensor connectors come pre-wired on the sensor body.

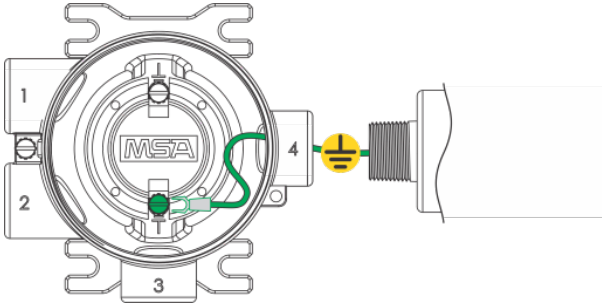

Figure 12 Grounding Sensor to Transmitter Housing

6. Verify the sensor connector is firmly seated on the terminal board.
7. Attach the sensor's ground to either of the grounding screws inside the ULTIMA X5000 housing.
8. Replace the board stack legs into the four depressions in the housing. Push firmly on the board stack where indicated (see Figure 13).

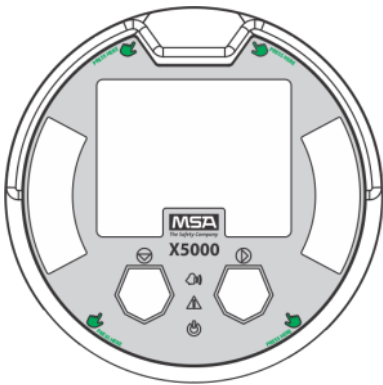

Figure 13 Highlighted areas show where to press when replacing a board stack.

NOTICE

- Avoid pressing on the left and right areas where the LEDs are located. Pressing directly on the display will damage the display and will void the warranty.
- Ensure that the electronics assembly is fully engaged in the mounting holes. If not fully seated, the user interface buttons may not function properly.

9. Replace the cover by turning clockwise.
10. Tighten the set screw located on the lid using a 1.5 mm Allen wrench.

3.4.5 Integrated Mounting Points

The ULTIMA X5000 transmitter can be surface mounted without any additional brackets using the integrated mounting tabs.

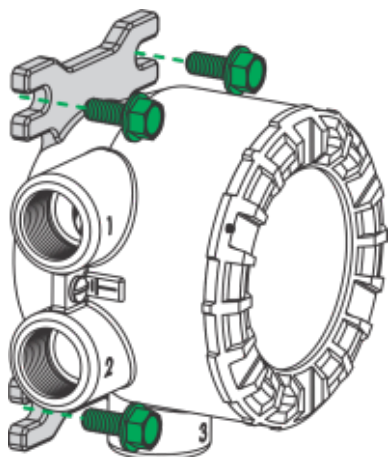

Figure 14 Internal Mounting Tabs (not compatible with ULTIMA XIR PLUS Sensors)

An supplementary mounting bracket is required for surface mounting the ULTIMA X5000 with an attached ULTIMA XIR PLUS sensor.

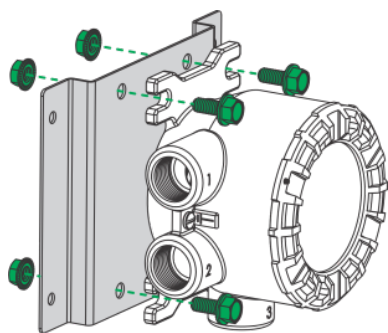

Figure 15 Mounting Bracket for ULTIMA X5000 (compatible with ULTIMA XIR PLUS Sensors)

3.4.6 Mounting Points JB5000 Junction Box

The JB5000 junction box can be mounted directly using the 4 integrated 10-32 threaded holes on the back of the enclosure or with the use of a mounting bracket (P/N 10206570).

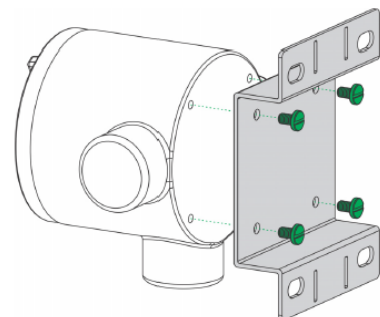

Figure 16 JB5000 Bracket Attachment

3 Installation

3.4.7 2" (50.8 mm) Pipe Mount

The integrated mounting tabs on the device housing can be mounted to a 2" (50.8 mm) pipe using a standard U-bolt. MSA provides U-bolts as an optional accessory (Part Number 10179873), however any 2" (50.8 mm) pipe U-bolt rated for the weight and dimensions of the ULTIMA X5000 can be used.

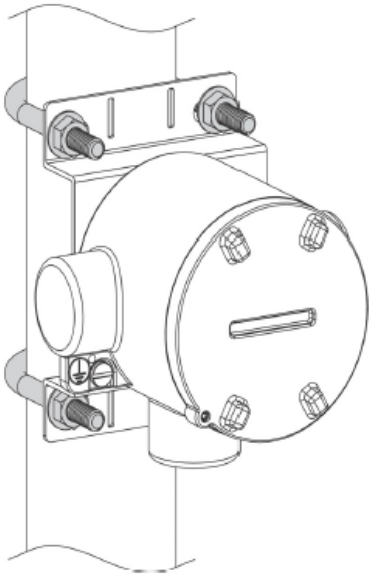

Figure 17 2" Pipe Mount with U-Bolt

3.4.8 Adjustable Pipe Mount

A Universal Pipe Mount Kit (P/N 10176946) can be used to mount the ULTIMA X5000 on pipes ranging from 1-6" (20-150 mm) in diameter. Two brackets are mounted over top of the integrated mounting tabs and fitted with an adjustable pipe band (not included).

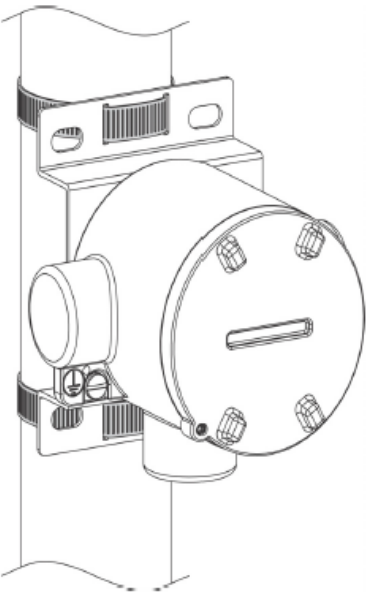

Figure 18 Adjustable Pipe Mount

3.4.9 Duct Mount

Duct mount kits are available for monitoring atmosphere inside flat or round ducts. Round duct mount kits are available for small ducts 12-20" (305-508 mm) in diameter (P/N 10179124) and large ducts 20-40" (508-1016 mm) in diameter (Part Number 10179321). The flat duct mount (P/N 10176947) is universal for flat ducts.

NOTICE

Consider the sensor type before choosing a duct mount location. ULTIMA XIR PLUS sensors should be mounted horizontally and all other sensors should be mounted vertically.

NOTICE

Air flow in the duct must be zero to ensure proper calibration.

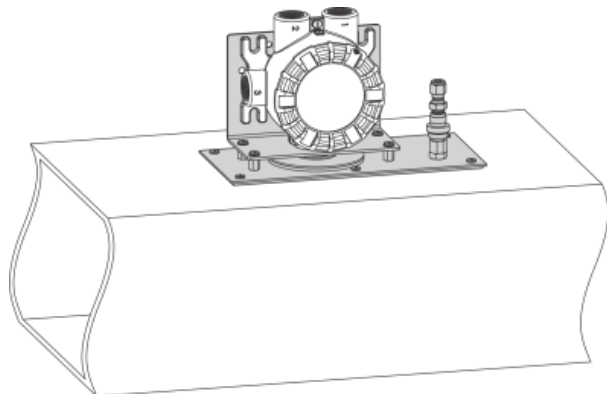

Figure 19 Flat Duct Mount

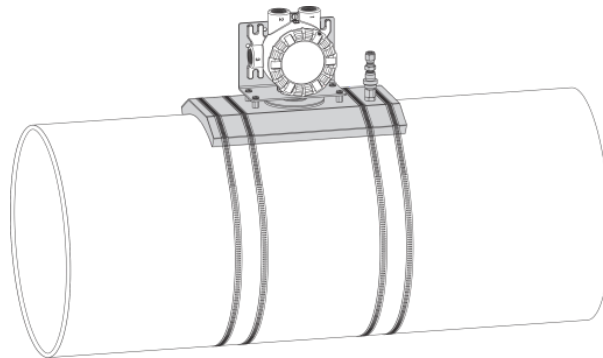

Figure 20 Round Duct Mount

3.4.10 Mounting with a Sunshield

A sunshield is required to protect the ULTIMA X5000 from direct sun light (P/N 10180254). The sunshield can be used in any of the mounting configurations.

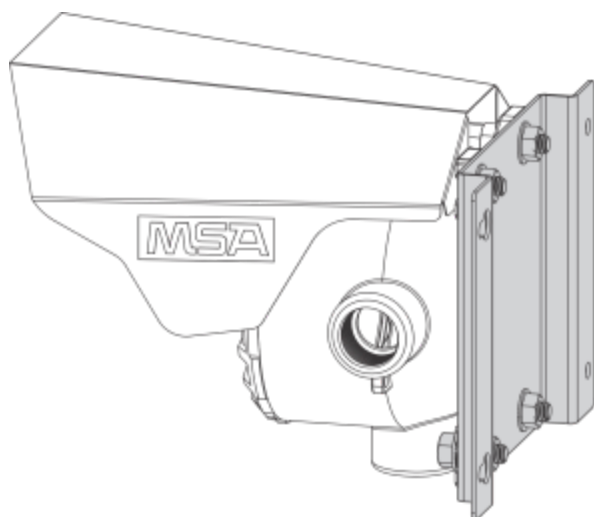

Figure 21 Sunshield with Wall Mounting Bracket

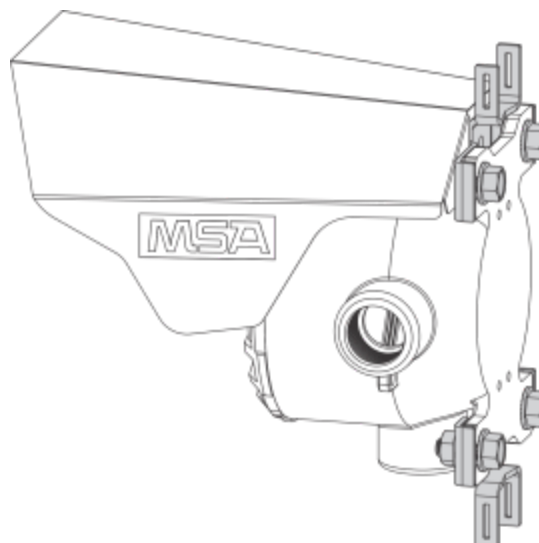

Figure 22 Sunshield with Universal Pipe Mount

3.4.11 Mounting with an SM5000 Sampling Module

An aspirated (P/N 10058101) and a DC pump (P/N 10043264) model are available for use with the X5000 with either digital or XIR sensors. For more information on mounting requirements and use with SM5000 sampling modules, see the SM5000 operating manual(s).

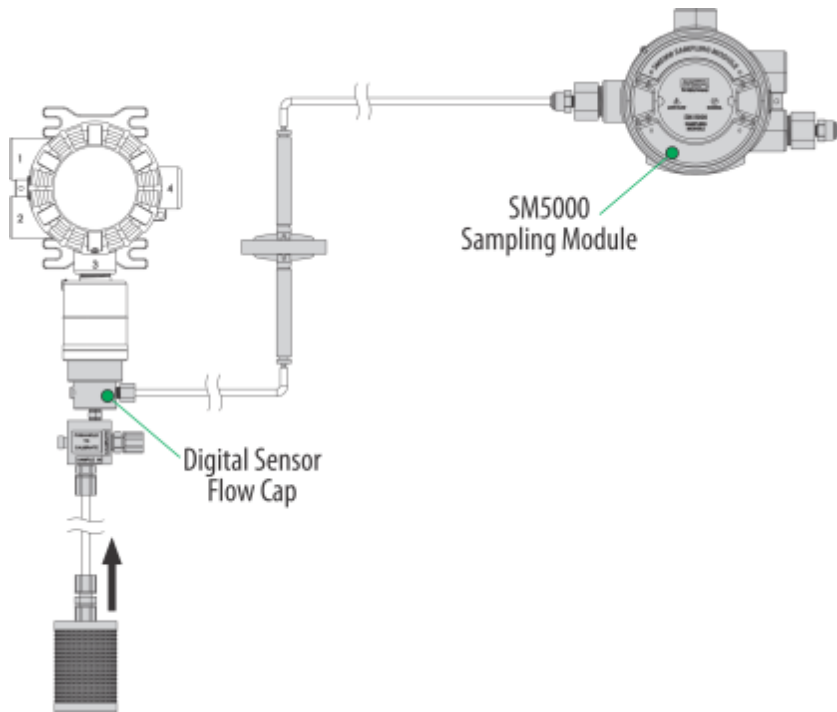

Figure 23 Mounting the SM5000 with Digital Sensor

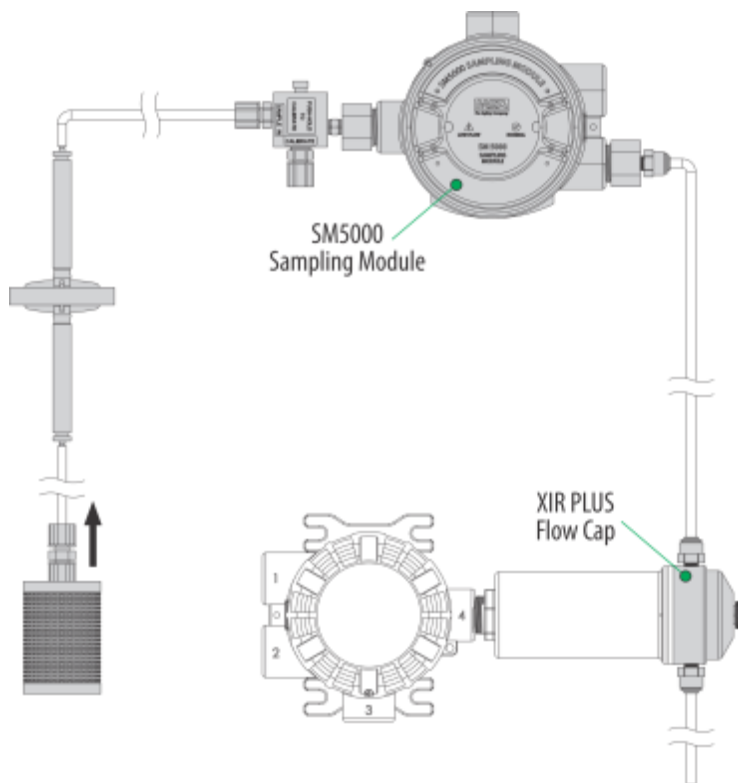

Figure 24 Mounting the SM5000 with XIR PLUS Sensor



SM5000 is not for sale in European Union.

Diffusion Supervision must be disabled when using the SM5000

3.5 Installing a Remote Sensor Junction Box

Sensors mounted remotely must use the ULTIMA X5000 or JB 5000 junction box. Only one sensor can be connected to each junction box. The junction box housing is the same construction as the ULTIMA X5000 transmitter. The mounting

options and instructions for connecting the sensor are the same for sensors connected directly to the ULTIMA X5000 transmitter housing. The junction box is available in 316 Stainless Steel.

Sensors can be remoted up to 328 ft (100 m) from the transmitter housing, as long as the ULTIMA X5000 transmitter is mounted within maximum distance from the power supply, as indicated in tables in [3.6.4 Power Load Requirements and Maximum Mounting Distances](#). The junction box does not have an illuminated display and has two connectors: a single sensor input and an output connecting to the transmitter. A 16 AWG (1.31mm²) 4 element cable with a braided shield should be used for the electrical connection between the junction box and the ULTIMA X5000 transmitter. Specific cable recommendations are Alpha wire 3248 or equivalent.



The X5000 junction box or JB5000 must be used for remote mounted sensors. The use of third party junction boxes may void product warranty.



Figure 25 Junction Box

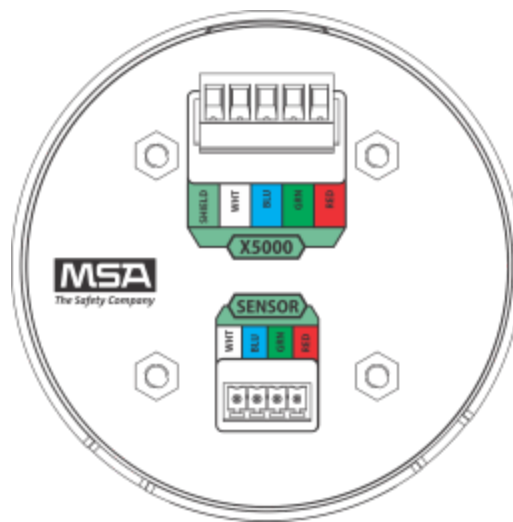

Figure 26 Junction Box Electrical Connections

If the remote sensor is not easily accessed, it is best practice to install tubing that can be used to apply calibration gas from the device display. Route the tubing to the ULTIMA X5000 Gas Monitor, ensuring that there are no kinks, leaks or other obstructions. Secure this tubing near the monitor.

3.6 Electrical Power Connections

3.6.1 Electrical Warnings - Read before Connecting Power

⚠ WARNING!

- Before wiring the ULTIMA X5000 transmitter, disconnect the power source supplying the transmitter and ensure no hazardous atmosphere present; otherwise, electrical shock or ignition of a hazardous atmosphere could occur.
- Install wiring in accordance with the electrical code of the country in use, the local authority having jurisdiction and these installation instructions, as applicable.
- Do not make any connections to the ULTIMA X5000 main board or junction box input, output, and relay connections while under power. Making connections under power could lead to electrical shock or ignition of a hazardous atmosphere.
- ULTIMA X5000 with relays are not approved for non-incendive wiring methods. Use of non-incendive wiring methods could lead to ignition of a hazardous atmosphere.
- Ensure that water and dirt are not able to enter the unit via the wire or conduit. If the unit is installed in a location known to be wet or damp, it is good practice to loop or bend the entry into the unit that prevents water incursion.
- The internal grounding terminal located in the base of the transmitter enclosure must be used for equipment grounding. The external grounding terminal is only to be used as a supplemental bonding connection where local authorities permit or require such a connection.

3 Installation

- As part of the product certification, it was verified that optional communication functions of this gas detection instrument while operating at the maximum transaction rate do not adversely affect the gas detection operation and functions of the instrument. The product certification, however, does not include or imply approval of the SafeSwap feature, communications protocol or functions provided by the software of this instrument or of the communications apparatus and software connected to this instrument.
 - Follow the warnings below when removing or replacing sensors. Reference [Figure 3](#) for component overview.
 - Never remove or replace a sensor body assembly or an Ultima XIR Plus while under power or when explosive hazards are present.
 - Confirm that the area is free of explosive hazards before removing or replacing an XCell Sensor under power.
 - To remove an XCell Sensor, unscrew XCell Sensor three full turns, wait 10 seconds, and then remove the XCell Sensor completely.

Failure to follow this warning can result in serious personal injury or death.

3.6.2 Retrofit Applications with UltimaX

The ULTIMA X5000 was designed to be easily retrofitted with existing UltimaX wiring. When replacing an existing UltimaX with the equivalent X5000 sensor technology, the following items need to be checked in order for the X5000 to operate:

- Wire gauge needs to be 18-14 AWG
- Sufficient power must be supplied to the X5000 in accordance with the maximum wire lengths (see tables 1-6).

If these requirements are met, performance of the X5000 should meet the noise immunity standard equivalent of the UltimaX using the existing wiring; However, the installation may not meet the latest EMC EN50270 noise immunity standard that the X5000 meets with the grounding and wiring scheme as indicated in I/O drawing SK3015-1051.

3.6.3 Electrical Hardware Requirements

Braided shielded, twisted pair, instrument quality wire or cable should be used to minimize the possibility of noise interference and contact with other voltages. Selection of shielded cable must comply with local requirements.

Conduit, in addition to braided shielded wire, may also be needed in areas where large amounts of electrical noise is expected. All cable shields should be terminated to earth ground at one end only.

The ULTIMA X5000's (RED) power connector terminals can accommodate up to 14 AWG (2.08 mm²). Four conductors are also required for the ULTIMA X5000 remote junction boxes. Use model # 10178512 for connection to 12 AWG (4.0 mm²) to adapt larger wire gauge to terminals.

Incoming power and signal cables should be a braided shield cable such as Alpha Wire 3248 or equivalent. The braided shield must be terminated to the instrument housing with a 360 degree connection to earth ground as shown in [Figure 29](#) or alternatively, the earth ground at the user's power source location. An external Class 2 power supply is required to supply 11-30 VDC to the ULTIMA X5000. Incoming power and signal cables should be a braided shield cable such as Alpha Wire 3248 or equivalent

3.6.4 Power Load Requirements and Maximum Mounting Distances

Consider future needs when selecting cable size and power supply. The maximum distance between the X5000 transmitter and the power supply depends on the sensor configuration (sensing technology and one or two sensors), wire gauge, and the power supply voltage. The tables below outline the maximum transmitter mounting distances. First determine if the sensor(s) will be locally or remotely mounted. Then choose sensor type(s). The corresponding nominal maximum power and mounting distances by wire gauge are shown.

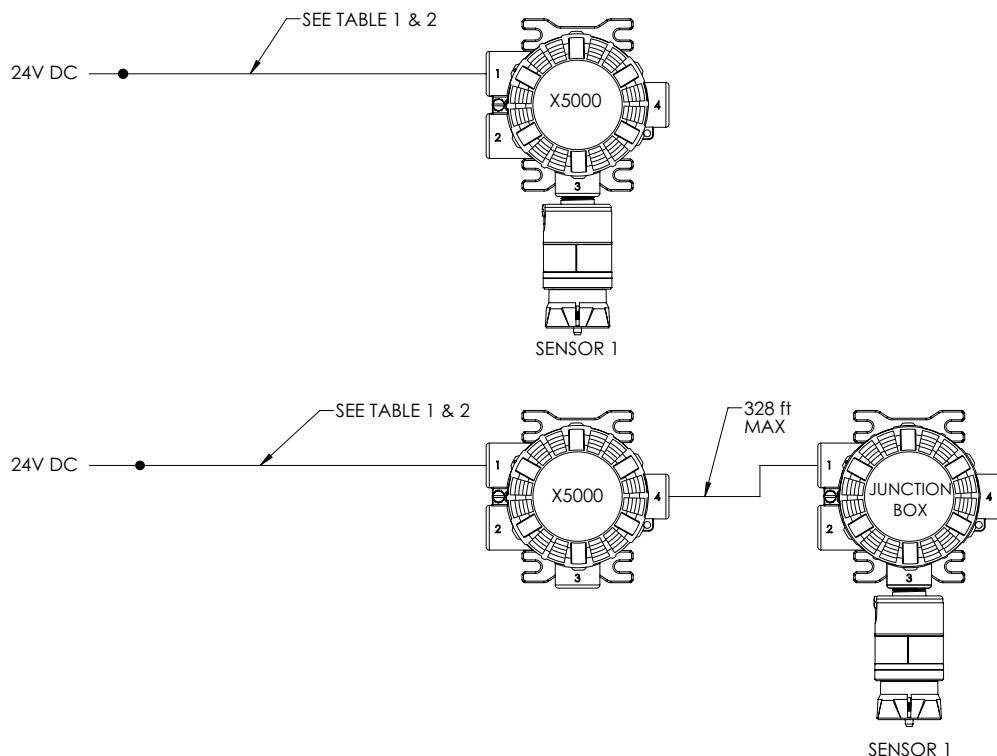

Figure 27 Single Sensor

Table 1 Maximum Wire Length to Main Transmitter with Single Sensor, Imperial Units

Sensor Mounting	Sensor 1	Max. Power ¹ (W)	Max. Distance (ft) to transmitter			
			24 VDC Supply			
			18 AWG	16 AWG	14 AWG	12 AWG
Mounted on transmitter	Echem	2.8	2211	3337	5314	8440
	Catalytic	4.9	1548	2335	3719	5907
	XIR PLUS	6.7	1184	1787	2846	4520
Remote mounted on junction box (up to 328 ft)	Echem	2.8	2210	3335	5313	8439
	Catalytic	4.9	1504	2294	3679	5867
	XIR PLUS	6.7	1090	1697	2759	4435

¹ When sizing a system's 24 V supply, a 1 A inrush current with a 1 ms duration should be considered for each ULTIMA X5000 on the power supply.

Assumes transmitter was ordered with relays

3 Installation

Table 2 Maximum Wire Length to Main Transmitter with Single Sensor, Metric Units

Sensor Mounting	Sensor 1	Max. Power ¹ (W)	Max. Distance in meters				
			24 VDC Supply				
			0.75 mm ²	1 mm ²	1.5 mm ²	2.5 mm ²	4 mm ²
Mounted on transmitter	Echem	2.8	597	796	1195	1989	3066
	Catalytic	4.9	417	557	836	1392	2146
	XIR PLUS	6.7	319	426	640	1065	1642
Remote mounted on junction box (up to 100 m)	Echem	2.8	596	795	1194	1988	3065
	Catalytic	4.9	404	544	823	1380	2134
	XIR PLUS	6.7	290	398	613	1039	1616

¹ When sizing a system's 24 V supply, a 1 A inrush current with a 1 ms duration should be considered for each ULTIMA X5000 on the power supply.

Assumes transmitter was ordered with relays

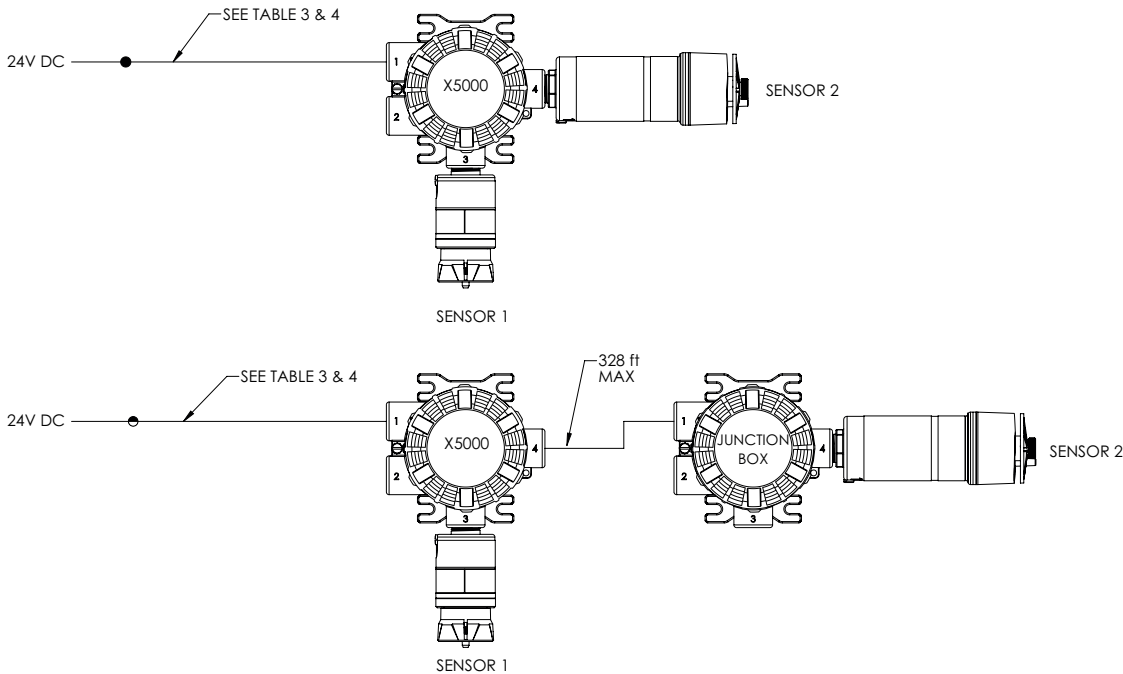

Figure 28 Two Sensors

Table 3 Maximum Wire Length to Main Transmitter with Two Sensors, Imperial Units

Sensor Mounting	Sensor 1	Sensor 2	Max. Power ¹ (W)	Max. Distance (ft) to transmitter			
				24 VDC Supply			
				18 AWG	16 AWG	14 AWG	12 AWG
Two sensors mounted on transmitter	Echem	Echem	3.6	2078	3136	4994	7932
		Catalytic	5.3	1473	2223	3541	5623
		XIR PLUS	7.0	1076	1623	2585	4106
	Catalytic	Echem	5.3	1473	2223	3541	5623
		Catalytic	10.6	1151	1736	2765	4392
		XIR PLUS	10.9	893	1347	2146	3408
	XIR PLUS	Echem	7.0	1076	1623	2585	4106
		Catalytic	10.9	893	1347	2146	3408
		XIR PLUS	11.6	* One sensor must be remote mounted if using two XIR PLUS sensors			
One sensor mounted on junction box (328 ft max), one sensor on transmitter	Echem	Echem	3.6	2096	3154	5012	7952
		Catalytic	5.3	1441	2193	3512	5596
		XIR PLUS	7.0	982	1536	2501	4024
	Catalytic	Echem	5.3	1441	2193	3512	5596
		Catalytic	10.6	1124	1711	2741	4368
		XIR PLUS	10.9	763	1225	2029	3295
	XIR PLUS	Echem	7.0	982	1536	2501	4024
		Catalytic	10.9	763	1225	2029	3295
		XIR PLUS	11.6	731	1135	1843	2961

- ¹ When sizing a system's 24 V supply, a 1 A inrush current with a 1 ms duration should be considered for each ULTIMA X5000 on the power supply.

Assumes transmitter was ordered with relays

3 Installation

Table 4 Maximum Wire Length to Main Transmitter with Two Sensors, Metric Units

Sensor Mounting	Sensor 1	Sensor 2	Max. Power ¹ (W)	Max. Distance in meters				
				24 VDC Supply				
				0.75 mm ²	1 mm ²	1.5 mm ²	2.5 mm ²	4 mm ²
Two sensors mounted on transmitter	Echem	Echem	3.6	561	748	1123	1869	2882
		Catalytic	5.3	397	530	796	1325	2043
		XIR PLUS	7.0	290	387	581	968	1491
	Catalytic	Echem	5.3	397	530	796	1325	2043
		Catalytic	10.6	310	414	622	1035	1596
		XIR PLUS	10.9	241	321	482	803	1238
	XIR PLUS	Echem	7.0	290	387	581	968	1491
		Catalytic	10.9	241	321	482	803	1238
		XIR PLUS	11.6	213	284	428	711	1096
One sensor mounted on junction box (100 m max), one sensor on transmitter	Echem	Echem	3.6	566	753	1128	1875	2887
		Catalytic	5.3	387	521	787	1316	2034
		XIR PLUS	7.0	261	359	555	942	1467
	Catalytic	Echem	5.3	387	521	787	1316	2034
		Catalytic	10.6	302	406	614	1028	1588
		XIR PLUS	10.9	200	283	446	768	1204
	XIR PLUS	Echem	7.0	261	359	555	942	1467
		Catalytic	10.9	200	283	446	768	1204
		XIR PLUS	11.6	195	266	409	694	1079

¹ When sizing a system's 24 V supply, a 1 A inrush current with a 1 ms duration should be considered for each ULTIMA X5000 on the power supply.

Assumes transmitter was ordered with relays

With dual sensors, and only one remoted at max length, add 6 m from the dual remoted sensor calculation.

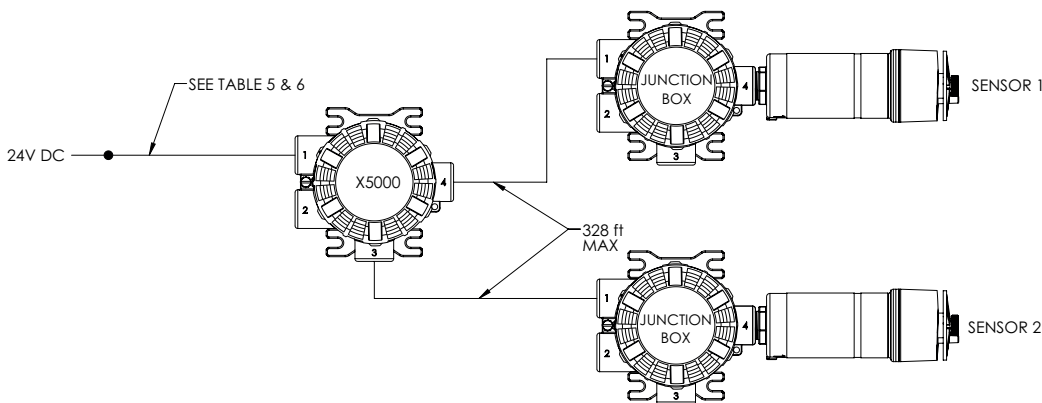

Figure 29 Two Remoted Sensors

Table 5 Maximum Wire Length to Main Transmitter with Two Remoted Sensors, Imperial Units

Sensor Mounting	Sensor 1	Sensor 2	Max. Power ¹ (W)	Max. Distance (ft) to transmitter			
				24 VDC Supply			
				18 AWG	16 AWG	14 AWG	12 AWG
Two sensors mounted on junction box up to 328 ft for 24V	Echem	Echem	3.6	2079	3134	4992	7932
		Catalytic	5.3	1421	2173	3492	5576
		XIR PLUS	7.0	962	1516	2481	4004
	Catalytic	Echem	5.3	1421	2173	3492	5576
		Catalytic	10.6	1104	1691	2721	4348
		XIR PLUS	10.9	743	1205	2009	3275
	XIR PLUS	Echem	7.0	962	1516	2481	4004
		Catalytic	10.9	743	1205	2009	3275
		XIR PLUS	11.6	711	1115	1823	2941

- ¹ When sizing a system's 24 V supply, a 1 A inrush current with a 1 ms duration should be considered for each ULTIMA X5000 on the power supply.

Assumes transmitter was ordered with relays

Table 6 Maximum Wire Length to Main Transmitter with Two Remoted Sensors, Metric Units

Sensor Mounting	Sensor 1	Sensor 2	Max. Power ¹ (W)	Max. Distance in meters				
				24 VDC Supply				
				0.75 mm ²	1 mm ²	1.5 mm ²	2.5 mm ²	4 mm ²
Two sensors mounted on junction box up to 100 m	Echem	Echem	3.6	560	747	1122	1869	2881
		Catalytic	5.3	381	515	781	1310	2028
		XIR PLUS	7.0	255	353	549	936	1461
	Catalytic	Echem	5.3	381	515	781	1310	2028
		Catalytic	10.6	296	400	608	1022	1582
		XIR PLUS	10.9	194	277	440	762	1198
	XIR PLUS	Echem	7.0	255	353	549	936	1461
		Catalytic	10.9	194	277	440	762	1198
		XIR PLUS	11.6	189	260	403	688	1073

- ¹ When sizing a system's 24 V supply, a 1 A inrush current with a 1 ms duration should be considered for each ULTIMA X5000 on the power supply.

Assumes transmitter was ordered with relays

3.6.5 Instructions for Power and Analog Output

WARNING!

Read all electrical warnings and wiring requirements before connecting power to the ULTIMA X5000.

3 Installation

Failure to follow this warning can result in serious personal injury or death.

The ULTIMA X5000 transmitter operates its analog output as a DC current source supporting a maximum load of 800 Ohms.

The red colored (4-pin) connector interfaces power and analog outputs 1 and 2. The HART interface is a separate, green colored (2-pin) connector.

The green colored (4-pin) connectors interface sensors one and two.

Using shielded cable is recommended. The cable shield should be terminated internal to the instrument enclosure using the crimp terminal provided (see [Figure 30](#)).

1. Remove the ULTIMA X5000 cover by turning counter-clockwise.
2. Pull on the metal bail, removing electronics, to expose sensor and power connections.
3. Remove the red colored power connector.
4. Use a small, flat head screw driver to open wire entries on the connector.
5. Strip cable jacket to expose shield and the four individual wires.
6. Connect the power and analog output wires. Wire locations are marked on the cover plate (see [Figure 30](#) [Figure 29](#)):
 - a. +DC
 - b. -DC
 - c. mA1 - *analog output of sensor 1*
 - d. mA2 - *analog output of sensor 2*

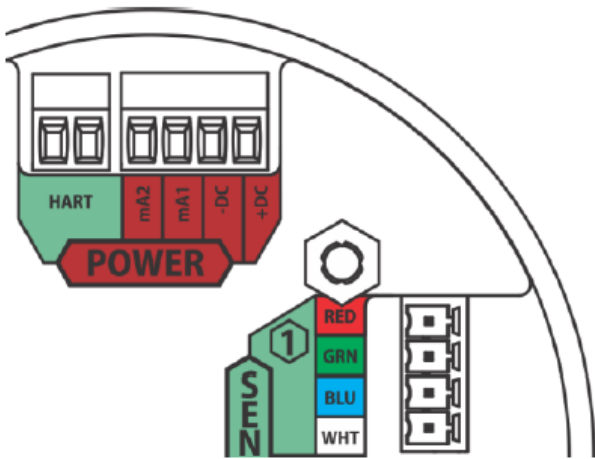

Figure 30 Power, HART, and Sensor Inputs

7. Tighten screws on connector and tug gently on wires to ensure they are secure.
8. Connect shield of cable to base of instrument housing (see [Figure 31](#) [Figure 30](#)).

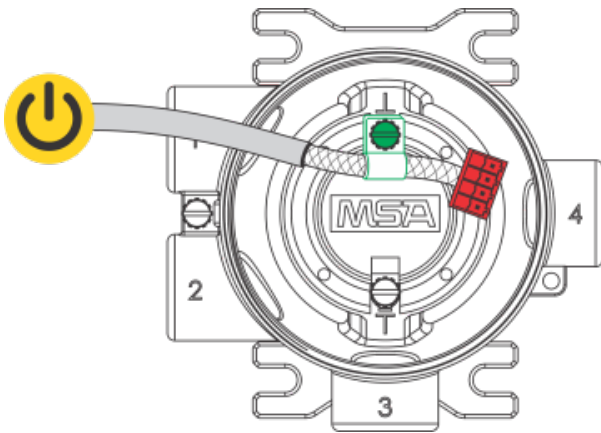

Figure 31 Connecting Power and Grounding Cable

9. Attach the connector to the board stack, making sure the appropriate wires are in the correct terminals.
10. Connect HART wires (for optional local HART port).
11. Connect an XCell or XIR PLUS sensor using the green connector. Sensor wires are already connected as shown on the cover plate (see [Figure 32 Figure 31](#)):
 - a. +DC (RED)
 - b. RS485 Com + (GRN)
 - c. RS485 Com - (BLU)
 - d. -DC (WHT)

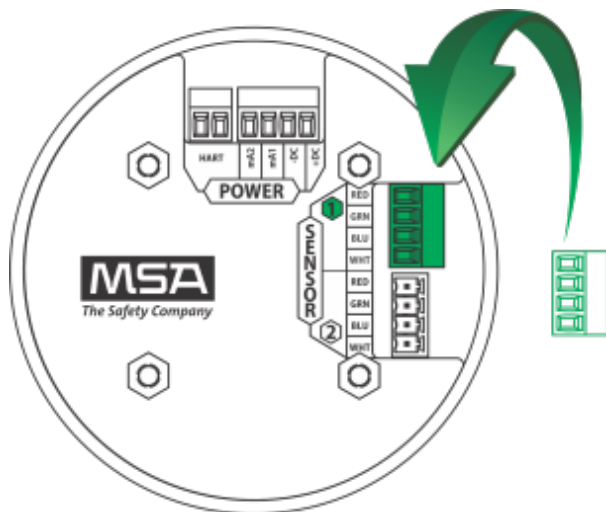

Figure 32 Connecting a Sensor to the Board

NOTE: Sensor connectors come pre-wired on the sensor body.

NOTE: Leaving exposed wire from the connector can electrically short the system.

12. Replace the board stack by aligning the four metal standoffs with the four holes inside the ULTIMA X5000 housing. Push firmly on the board stack where indicated (see [Figure 33](#)).

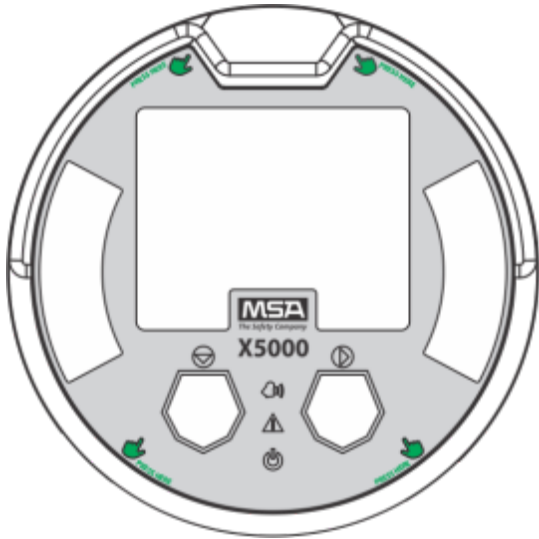

Figure 33 Highlighted areas show where to press when replacing a board stack

NOTICE

Ensure that the electronics assembly is fully engaged in the mounting holes. If not fully seated, the touch interface performance can be negatively affected

NOTICE

- Avoid pressing on the left and right areas where the LEDs are located. Pressing directly on the display will damage the display and will void the warranty.
- Care must be taken to insure the X5000 inside glass surface is free of smudges/dirt and grease. Dirt and grease can interfere with the touch interface of the display.

Table 7 ULTIMA X5000 Installation Outline Drawing

Model	Document No.
ULTIMA X5000	SK3015-1051

3.6.6 Relay and Power Connections

Relay Board Stack Overview

The ULTIMA X5000 can be purchased with three relays. Two of the relays can be configured for either de-energized (default) or energized and latching or non-latching (default). The third relay is a dedicated fault relay.

All electrical connections to internal relays can be made directly on the PC board. The board is labeled for Normally Open (NO) and Normally Closed (NC) de-energized state.

3 Installation

Relay Connections to Inductive Loads

If connecting the relays to motors, fluorescent lighting, or other inductive loads, it is necessary to suppress any sparks or inductive feedback that may occur at the relay contact. These effects may render the unit inoperative.

One way to reduce these effects is to install a Quencharc[®] (P/N 630413) across the load being switched.

Fault Relay Wiring and Configurations

The Fault Relay state in non-fault operating condition is Energized and terminal connections are supplied for Normally Closed and Normally Open.

The energized fault relay setting provides an electrical path for fail-safe relay operation. In the event of any failure, including loss of power, the relay will change to the de-energized state to indicate a fault condition.

The Fault Relay state cannot be reconfigured.

Relay Energy State and Terminal Connections

The ULTIMA X5000 relays can be selected as energized or de-energized on the device. The default configuration is the De- Energized state. The preferred relay energy state should be determined before making connections. [Table 9](#) shows the terminal connections by energy state and is applicable to both relay 1 and relay 2.

Table 9 Relay Terminal Connections by Energy State

Energy State	NC (Normally Closed)	NO (Normally Open)
De-Energized (default)	Closed	Open
Energized	Open	Closed

4 Operation

WARNING!

Refer to manual addendum (P/N 10182779) for Certification Information and additional safety information before installation and operation.

Failure to follow this warning can result in serious personal injury or death.

The ULTIMA X5000 Series transmitter is factory calibrated and shipped with the most common default options to minimize set up effort. Any of the default settings can be changed to meet the user's individual needs via the EZ touch buttons on the display of the ULTIMA X5000.

4.1 Startup

4.1.1 Initial Startup

The first time the ULTIMA X5000 is powered on, the analog output goes to the Maintenance Mode setting (default 3.5 mA) and the following will appear on the display while the LEDs cycle from GREEN, to RED, to AMBER, then to GREEN:

- ULTIMA X5000 Logo with Software Version No.
- Tachometer countdown
- MSA Logo

The ULTIMA X5000 will remain in start-up mode in which the fault relay is energized and the analog output is at its maintenance level, 3.5 mA by default. The time the X5000 stays in start-up mode is dependent on the warm up time of the sensor. See [4.1.2 Sensor Warm Up Times](#) for each sensor. If a dual sensor configuration is deployed, each sensor is able to exit warm up independently.

A full calibration is recommended after one hour of a sensor being installed, powered up, and acclimated to the environmental conditions. See [5 Calibration](#) for details.

4.1.2 Sensor Warm Up Times

WARNING!

For optimal sensor performance, allow sensors 24 hours (72 hours for ETO) to acclimate to application conditions before performing an initial calibration.

Failure to follow this warning can result in serious personal injury or death.

XIR PLUS: ≤ 5 min	CO: 30 min (see below)	NO ₂ : ≤ 5 min
H ₂ S: ≤ 5 min	O ₂ : 30 min	CLO ₂ : ≤ 5 min
SO ₂ : ≤ 5 min	HCL: ≤ 10 min	HCN: ≤ 5 min
Cl ₂ : ≤ 10 min	HF: ≤ 5 min	H ₂ : ≤ 5 Min
NH ₃ : ≤ 5 min	ETO: ≤ 60 min (see below)	Low O ₂ : ≤ 30 min
Cat Bead: ≤ 5 min	NO: ≤ 10 min	

Carbon monoxide and ethylene oxide sensors, gas codes 10, 11, 12, 14, and 71 may require initial warm-up periods longer than 30 minutes. If the 30-minute warm up is over, the sensor may show a positive reading that exceeds alarm levels. In the event of a short-term power outage, the warm-up time for carbon monoxide and ethylene oxide sensors will be significantly less. See [Table 10 Warm Up Times](#) to estimate required warm-up time.

4 Operation

Table 10 Warm Up Times

Reading Level	< 10ppm ¹	< 1ppm
Time left unpowered	Time to warm up	
1 min	≤ 5 min	≤ 5 min
8 hours	≤ 30 min	≤ 30 min
5 days	≤ 30 min	2-4 hrs
1 month	≤ 2 hrs	6-10 hrs

- ¹ The minimum alarm level of the CO sensors is 15 PPM and the ETO sensor is 1 PPM. Below this level would not cause an alarm on the device.

4.2 Settings

The ULTIMA X5000 is a tool free transmitter. The two EZ touch buttons on the face of the display can be used to navigate through the menu structure. The buttons are designed for use with fingers with a “press” and “release” action, and work best without gloves.

Table 11 Navigating through the menu structure

Button	Function
left button (↓)	scrolling through each menu
right button (→)	selecting a particular menu option

Changing a value

1. Select the relevant option with →.

The arrow disappears and the first digit to change appears underlined.

2. Scroll through the numbers with ↓.
3. Use → to move on to the next digit.

When the arrow reappears, the value changing is finished.

When entering a new value, remember the following to ensure settings are saved:

- Use *SAVE* before exiting or settings will be lost.
- Use *BACK* to go back to previous screen.
- Use *CANCEL* to go back to main settings menu (i.e. *BACK*).
- Use *HOME* to return to gas reading display.

4.2.1 Instrument Settings

The following settings are saved to the device memory and will not change if the sensor type is changed.

1. Scroll to Settings.
2. Select Instrument.
3. Select to enter the menu.

Table 12 Default Device Settings

Setting		Default	Menu 1 Options	Menu 2 Options
Relay Setup	Relay State	De-energized (Fault Relay always energized)	Relay 1 Relay 2	De-energized Energized
	Mapping	Common	Relay 1 Relay 2	Common Discrete Horn
Analog Settings (see Table 13)		Custom 1 (see Table 13)	3.5mA with HART 1.25mA with HART Custom 1 Custom 2	Custom Settings Calibration Cleaning mode ¹ Fault Maintenance
Cal Alert		Disabled	Enable Disable	(none)
Bluetooth		Enabled	Bluetooth Status Reset All	Enable Disable Reset All
Min/Max/Avg		1h	Interval (1h, 8h, 24h) Start Hour (0-23h)	
Swap Delay		Enabled	Enable Disable	
Set Date		UTC-5(Factory Date and Time)	Year (2000-2999)Month (Jan-Dec)Day (0-31)Time (0:00-23:59)	
Password		Disabled	0000-9999, incr. 0001	
Controller Data Reset		N/A	Controller Data Reset	
Display Units		Sensor Dependent (see Table 14)	PPMmg/m ³ µMol%Vol	
Tag #		Blank	Only configurable via HART and Bluetooth	
Reset Main Unit		N/A	Reset Main Unit	

¹ Cleaning mode not available

Setup Relay State for Energized or De-Energized

Relays 1 and 2 are default De-energized. Relay 3 is a fault relay that is set to Energized and cannot be changed.

4 Operation

To set Alarm Relay State:

1. Scroll to Settings.
2. Select Instrument.
3. Select Relay Setup.
4. Select Relay State.
5. Select Relay 1 or Relay 2.
6. Select Energized or De-Energized.

Relay Mapping

Relay 1 and Relay 2 can be configured for common, discrete, and horn modes via the device display menu or X/S Connect app. Common mode is the default relay mapping setting. In Common mode, Relay 1 is actuated by Alarm 1 on either sensor, and Relay 2 is actuated by Alarm 2 on either sensor.

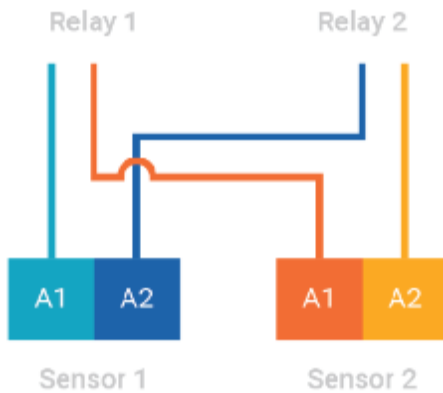

Figure 37 Common Mode Relay Map and Alarm Actuation

Discrete mode allows a separate action for each sensor. Relay 1 is actuated by Sensor 1 alarms and Relay 2 is actuated by Sensor 2 alarms.

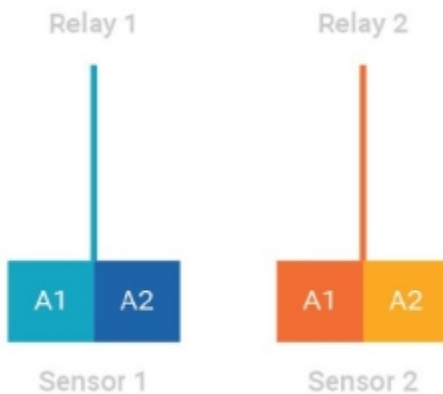

Figure 38 Discrete Mode Relay Map and Alarm Actuation

Horn mode is designed to allow local acknowledgment of a relay-triggered horn, while the alarm state is still present. All alarms on both sensors trigger both relays, however the second relay can be acknowledged by pressing one finger over each of the EZ touch buttons and holding for 1 second before releasing.

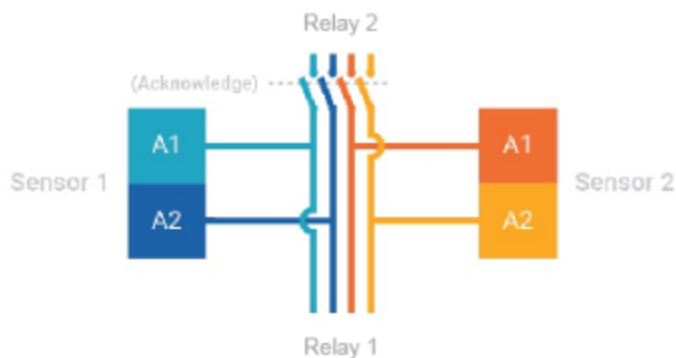

Figure 39 Horn Mode Relay Map and Alarm Actuation

Analog Output Settings for Fault Conditions

Analog outputs can be set to 3.5 mA and 1.25 mA with HART, or to custom output values as listed in [Table 13](#). Output settings for oxygen sensors are not configurable. The Maintenance analog output is used during start up, Reset Main Unit, and Controller Data Reset.

To change Analog outputs settings:

1. Scroll to Settings.
2. Select Instruments.
3. Scroll and Select Analog Settings.
4. Select 3.5, 1.25, Custom 1 or Custom 2.
5. Select Save.
6. (Only Custom) Select Fault, Calibration, or Maintenance.
7. (Only Custom) Enter desired output levels (options in [Table 13](#)).
8. (Only Custom) Select Save.
9. (Only Custom) Repeat for remaining outputs.
10. Select Save.

Table 13 Analog Output Setting Options

Output Setting (mA)	3.5 mA	1.25 mA	Custom 1 Default ¹	Custom 2 Default	Fault Relay Action	AO Range Options
Fault	3.5 ²	1.25 ²	2.0	2.0	Open, Latching	Range: 0.000-3.750 Increment: 0.025
Calibration Mode (excl. O ₂)	3.5 ²	1.5 ²	3.0	3.0	Closed, No Action	Range: 0.000-3.750 Increment: 0.025
Cleaning Mode (NOT ENABLED)	3.5 ²	2.0 ²	2.5	2.5	Closed, No Action	Range: 0.000-3.750 Increment: 0.025
Maintenance	3.5 ²	3.5 ²	3.5	3.5	Closed, No Action	Range: 0.000-3.750 Increment: 0.025
O ₂ Calibration Mode	3.5 ²	1.5 ²	21.7 ³	Same as Calibration	Closed, No Action	Range: 0.000-3.750 Increment: 0.025
Cal Alert	3.5	3.0	3.0	3.0	Closed, No Action	Range: 0.000-3.750

4 Operation

Output Setting (mA)	3.5 mA	1.25 mA	Custom 1 Default ¹	Custom 2 Default	Fault Relay Action	AO Range Options
						Increment 0.025
Zero Reading	4.04 ²				Closed, No Action	
Over Range	21.7 ²				Closed, No Action	

¹ Default factory setting

² Not configurable

³ For an O₂ sensor, 21.7 mA is the default Custom 1 setting and is not configurable.

Calibration Alert

XCell H2S and CO sensors with TruCal technology actively monitor sensor and adjust sensitivity without any manual intervention. When equipped with Diffusion Supervision, TruCal will also monitor the sensor inlet for obstructions while Diffusion Supervision is enabled. These sensors do not need to be calibrated on a static maintenance cycle. When a manual calibration is recommended, the sensor will detect this and slow flash either the left green LED or right green LED indicating that calibration is recommended for sensor 1 or sensor 2 respectively. Users can also enable Calibration Alert so that an analog output signal is sent to the control room when a calibration is recommended. Whether or not the calibration alert is enabled, if gas is detected by the sensor, the ULTIMA X5000's analog output and display will follow the gas reading.

To Enable Calibration Alert:

1. Scroll to Settings.
2. Select Instrument.
3. Scroll and select *Cal Alert*.
4. Select *Enable Cal Alert*.
5. Scroll and select *Save*.

Enable Bluetooth Communications

Every ULTIMA X5000 ordered with Bluetooth comes with the communications enabled by default. Bluetooth must be enabled for any Bluetooth functions to operate. A compatible Bluetooth host with the X/S Connect App is needed for connection.

To disable Bluetooth:

1. Scroll to Settings.
2. Select Instrument.
3. Scroll and select Bluetooth.
4. Select Bluetooth Status.
5. Select Disable.
6. Select Save.



Devices ordered without Bluetooth do not contain a Bluetooth chip, but may show Bluetooth as a menu option. On these devices if a user tries to enable Bluetooth, it will appear as though the enable setting is not being saved. Check the product configuration. If the third value is a non-zero value, it may be ordered without Bluetooth.

Bluetooth Pairing

The instrument memory has the ability to store up to 25 mobile devices in its memory.

As a visual indication, the green LEDs will toggle and quickly flash when a device is paired.

Once paired with an X5000, the user will be able to connect to the same X5000 remotely and without needing to enter a pairing code, unless over 25 other devices are paired with the same X5000 afterwards.

To pair with the X5000:

1. Download the X/S Connect App from the Google Play Store or the iOS App Store.
2. Open the X/S Connect App.
3. Select “Connect” for the X5000 that you would like to connect with.
4. (First Time Only) When prompted, tap EZ touch button to display a 6-digit pass code.
5. Enter Pairing Code shown on X5000 display.

Bluetooth Security

The Bluetooth connection is encrypted and secured with a unique six digit pin that must be confirmed on the mobile device and acknowledged on the detector display. All of the previously paired devices can be erased from the X5000 to provide additional security and control.

To Reset All device pairings:

1. Scroll to Settings.
2. Select Instrument.
3. Scroll and select Bluetooth.
4. Scroll and select Reset All.
5. Select Continue.

NOTICE

Reset All will delete all paired device memory. All devices will have to re-initiate pairing at the device.

Bluetooth Tag ID

See [4.3 Status Menu](#) to view Bluetooth Tag ID.

Min/Max/Average

The minimum, maximum, and average gas readings can be set for a user-defined interval. For example, if the interval is set to 24 and the start hour is set to 6, the Min/Max/Avg values will update every 24 hour period starting at 6 am.

The default interval is set to 1h and start hour is 0. The Interval and Start Hour are driven by the Time and Date of the transmitter.

To change Min/Max/Average interval and time:

1. Scroll to Settings.
2. Select Instrument.
3. Scroll and select Min/Max/Average.
4. Select Set Interval.
5. Enter Interval (1h, 8h, 24h) and Save.
6. Scroll to Set Start Hour.
7. Enter Start Hour (0-24h) and Save.



The Min/Max/Average values are only viewable through the X/S connect app or HART.

Swap Delay

Swap Delay allows the user a brief window to change an XCell sensor without the device going into a fault condition. Once a sensor is disconnected from the transmitter, the user will have 2 minutes to reconnect a sensor. During this time, the device analog output will go to its Maintenance level. If a sensor is reconnected or replaced during the 2 minute window, the new sensor's countdown sequence will begin and the analog output will remain at the Maintenance level. After the sensor countdown is complete, the analog output will return to reporting a live gas reading. If a sensor is not reconnected

4 Operation

after the 2 minute window, the ULTIMA X5000 will enter a “Sensor Missing” fault condition. All XCell Sensors have SafeSwap and do not need to be disconnected from power while changing sensors. For more details on how to change sensors, see [6.2 Replacing an XCell Sensor](#). Swap Delay is enabled on all ULTIMA X5000 transmitters by default.

NOTICE

The transition to maintenance mode during the 2 minute Swap Delay window and sensor countdown will not trigger the Fault Relay. The Fault Relay will only be triggered when the device enters a fault condition.

To enable or disable Swap Delay:

1. Scroll to Settings.
2. Select Instrument.
3. Scroll and select Swap Delay.
4. Select Enabled or Disabled.
5. Select Save.

Time and Date Setup

Time and date are set at the factory in GMT. When selected, the current date is displayed. Select Change to edit date and time. The user must save to move onto the next date setting. The Min/Max/Average settings are driven by the date and time and should be changed to local time for data accuracy.

To change Time and Date:

1. Scroll to Settings.
2. Select Instrument.
3. Scroll and select Set Date.
4. Scroll and Select Change.
5. Select Year and Save.
6. Select Month and Save.
7. Select Day and Save.
8. Set Time and Save.



You can also use the X/S Connect App to sync time and date with a mobile device.

Enable Password

Enabling password will require the user to enter the password before entering any of the settings menu. The password entry screen defaults to 0000 and is disabled by default.

NOTE: In order to maintain compliance to 60079-29-1, the password must be enabled and set to a non-default value. In addition, an access barrier must be implemented for Modbus and HART communication to prevent parameter changing by unauthorized persons.

When the password is enabled, a lock icon will appear in the top right corner of the display.

If the password is lost, call MSA Customer Service at 1-800-672-2222.

To enable the password:

1. Scroll to Settings.
2. Select Instrument.
3. Scroll and select Password.
4. Select Enable Password.
5. Scroll and select Save.
6. Confirm the Password (password is default 0000 until changed).

Change Password

A password can be changed whether or not the password is enabled.

If the password is lost, call MSA Customer Service at 1-800-672-2222.

To change the password:

1. Scroll to Settings.
2. Select Instrument.
3. Scroll and select Password.
4. Select Change Password.
5. Enter desired password.
6. Select Save.
7. Scroll and select Save to confirm password.

Language

The ULTIMA X5000 main display can be viewed in multiple languages. Available Languages are: English, French, Spanish, Portuguese, Italian, Dutch, Russian, Chinese, and German.

The X/S Connect App is only available in English, and does not change when the display language on the ULTIMA X5000 is changed.

To change the display language:

1. Scroll to Settings.
2. Select Instrument.
3. Scroll and select Language.
4. Select English, French, Spanish, Portuguese, Italian, Dutch, Russian, Chinese, or German.
5. Scroll and select Save.

Controller Data Reset

Controller Data Reset will reset all of the settings in the main PCBA to their factory defaults and cycle power to the unit.

To reset data to factory default values:

1. Scroll to Settings.
2. Select Instrument.
3. Scroll and select Controller Data Reset.
4. Select Continue.

The unit will reboot, and the analog output will go to the values entered for Maintenance.

Display Units

The default display units are dependent on the sensor type. See Tab 9 for default sensor units. Only % LEL is available for combustible sensors. Only % is available for oxygen sensors.

To change display units:

1. Scroll to Settings.
2. Select Instrument.
3. Scroll and select Units.
4. Select PPM, mg/m³ or µMol.
5. Scroll and select Save.

4 Operation

Tag Number

Displays current tag. Default is blank. Below are the valid characters one can enter to identify their unit. Entering the tag is only available via the X/S Connect App and HART. When changed, this will be the name used by the transmitter for advertising Bluetooth signal.

	0	1	2	3	4	5	6	7	8	9	A	B	C	D	E	F
0	@	A	B	C	D	E	F	G	H	I	J	K	L	M	N	O
1	P	Q	R	S	T	U	V	W	X	Y	Z	[\]	^	_
2	SP	!	"	#	\$	%	&	'	()	*	+	,	-	.	/
3	0	1	2	3	4	5	6	7	8	9	:	;	<	=	>	?

Figure 40 Valid Characters

Reset Main Unit

Reset Main Unit will cycle power on the instrument, without changing any of the settings.

To reset the main unit:

1. Scroll to Settings.
2. Select Instrument.
3. Scroll and select Reset Unit.
4. Select Continue.

The unit will reboot, and the AO will go to the values entered for Maintenance.

4.2.2 Sensor Settings

The following settings are saved to the ULTIMA X5000 so that if the sensor is replaced with the same sensor type (gas and range), the settings will remain the same. If a different sensor type and range is used to replace the previous sensor, the new sensor's default settings will upload to the device.

To change sensor settings:

1. Scroll to Settings and select it.
2. Select Sensor.
3. Select an option to enter the menu.

Alarm Set Points

There are two configurable alarm set points for each sensor. Alarm set point maxima are limited to the full scale range of the sensor. Alarm minima are listed in [Table 14](#).

To change alarm set points:

1. Scroll to Settings and select it.
2. Select Sensor.
3. Select Alarm Setup.
4. Select Alarm Set Points.
5. Enter desired alarm set point (this will be limited by sensor range).
6. Scroll and select Save.

Alarm Actions

Relays can be triggered by an alarm threshold as gas readings increase or decrease. Most applications require increasing alarm thresholds, except for Oxygen monitoring, which is most often a decreasing alarm. Relays can also be triggered such that the relays are latched in the alarm state until a user acknowledges the alarm by placing one finger over each of the EZ touch buttons and holding for 1 second before releasing. If the alarm relay state is chosen to be Non-Latching, the relay will reset once the alarm condition (gas value) returns to a value outside of the alarming condition. A user can also disable alarms in the Alarm Actions menu.

To change alarm actions:

1. Scroll to Settings and select it.
2. Select Sensor.
3. Select Alarm Setup.
4. Scroll and select Alarm Actions.
5. Select Sensor 1 or Sensor 2.
6. Select Alarm 1 Actions or Alarm 2 Actions.
7. Select Disabled, Increasing/Non-Latching, Increasing/Latching, Decreasing/Non-Latching, or Decreasing/Latching.
8. Scroll and select Save.

Span Value

The span value is used to set the calibration point. The default span values are approximately half of the total range of the sensor as purchased (see [Table 14](#)). If the range is changed, the span value should also be changed to increase accuracy over the full scale range.

Before changing the span value, the user should ensure that the appropriate concentration of calibration gas is available. The concentration of the calibration gas should match the span value, except if using propane to calibrate a combustible sensor to a different gas cross reference value.

To change the span value:

1. Scroll to Settings and select it.
2. Select Sensor.
3. Scroll and select Span Value.
4. Current Span Value is displayed.
5. Enter desired span value.
6. Scroll and select Save.



Default and range of available span values depends on the sensor type. See [Table 14](#) for default and range of span values.

4 Operation

Sensor Range

All XCell sensors have adjustable sensor ranges. The sensor range cannot be set below the current alarm set points. The user may need to first lower alarm set points and/or span value in order to adjust sensor range to desired level. The user should also consider adjusting the span value to accommodate the changed sensor range so that the span is in the center of the range.

To change the sensor range:

1. Scroll to Settings and select it.
2. Select Sensor.
3. Scroll and select Sensor Range.
4. Current sensor range is displayed.
5. Enter desired sensor range.
6. Scroll and select Save.



Changing the sensor range will change the analog output values for alarm levels.

Gas Table

The ULTIMA XIR PLUS combustible sensor can be calibrated to a wide range of compounds, see [9 Appendix: Calibration Guide for Additional Gases](#) for a list of gases, span values, and gas table values.



The XIR PLUS sensor is only performance approved for Methane and Propane.

Gas Table #	Target Gas
1	Methane
2	Propane
3	Ethane
4	Butane
5	Pentane
6	Hexane
7	Cyclopentane
8	Ethylene

Note that the Gas Table numbers listed above represent different linearity curves for infrared absorbing gases. Typically, higher Gas Table numbers represent weaker absorbing gases. Each curve represents a linearity that is applicable to a group of hydrocarbon gases and not necessarily one specific gas. The Target Gas shown is representative of a group of gases with similar linearity.

WARNING!

The XIR PLUS sensor must be calibrated after changing the gas table and/or span value.

Failure to follow this warning can result in serious personal injury or death.

Reset Sensor

The sensor default values can be restored by resetting the sensor. If Swap Delay is enabled, during a sensor reset the analog outputs will behave the same as if a sensor were replaced. See the section on Swap Delay for details. If Swap Delay is disabled the analog outputs will first go into a fault condition, followed by the maintenance condition for the duration of the sensor's countdown.

NOTICE

The sensor goes into a Sensor Configuration Reset fault and must be calibrated after a sensor reset. There will be four dashes displayed where the current reading should be. All settings, including Alarm Set Point and Calibration Values, will be returned to factory defaults.

To Reset Sensor to factory default:

1. Scroll to Settings and select it.
2. Select Sensor.
3. Scroll and select Reset Sensor.
4. Select Continue.

NOTE: Sensor Reset can take 10 seconds to initiate the sensor's countdown.

5. Calibrate the sensor to clear Sensor Configuration Reset fault.

Disable Sensor

When removing a sensor from the transmitter while under power, the ULTIMA X5000 will enter a Sensor Missing fault condition after the two minute Swap Delay period has expired (if enabled). If Swap Delay is disabled, the transmitter will go into Sensor Missing fault immediately after removing the sensor from the transmitter. If the system is off at the time a sensor is removed, the transmitter will go into fault after its startup sequence. This fault condition can be removed by disabling the affected sensor position.

Disabling a sensor removes the fault and stops communications with the sensor, the sensor's reading on the display is removed, and the mA channel for that sensor position is set to 0 mA. By default, the ULTIMA X5000 has the Sensor 2 position disabled. If at any time a sensor is connected to a position that is disabled, the ULTIMA X5000 will automatically enable that sensor position.

To disable the sensor after removal:

1. Scroll to Settings and select it.
2. Select Sensor.
3. Scroll and select the sensor you want to disable (Sensor #1 or Sensor #2).
4. Scroll and select Disable Sensor.



Only one sensor can be disabled at a time. The transmitter will not allow both sensor positions to be disabled simultaneously.

The ULTIMA X5000 only allows a sensor to be disabled after the transmitter has gone into Sensor Missing fault.

Diffusion Supervision

Diffusion supervision actively monitors the sensor inlet for obstructions. If an obstruction is detected, the sensor will go into a fault mode to alert users and the control room that it is not capable of detecting gas due to an obstruction.. Objects residing directly on or in the sensor inlet that result in a significant impact to the gas path are very likely to be detected by Diffusion Supervision. Examples include paint, tape, water, and dirt. Small amounts of these materials can be visible on the inlet while not impacting the gas path enough to trigger a Diffusion Supervision Fault. A fault signal will only be sent out when the system determines that the amount of material that has accumulated on or inside the sensor inlet is negatively affecting the gas path.



Even if a Diffusion Supervision Fault has not been triggered, it is good practice to clear any foreign material from the sensor inlet if any is observed while inspecting the sensor.

To enable or disable Diffusion Supervision:

1. Scroll to Settings and select it.
2. Select Sensor.
3. Scroll and select *Diffusion Supervision*.

4. Scroll and select *Enable* or *Disable*.
5. Scroll and select *Save*.

Table 14 Default Sensor Settings

Gas (Code)	Thread Type ⁴	TruCal	Range Default	Display Resolution ³	Unit Default	Alarm 1 Default	Alarm 1 Default AO (mA)	Alarm 2 Default	Alarm 2 Default AO (mA)	Alarm Action Default	Span Value Default	Alarm Min	Alarm Max	Range Min	Range Max	Span Value Min	Span Value Max
Ammonia (40)	Coarse	○	0-100 PPM	1	PPM	10	5.6	20	7.2	Increasing Non-Latch	25	3	100	0-25	0-100	25	FS ¹
Ammonia (41)	Coarse	○	0-1000 PPM	10	PPM	100	5.6	200	7.2	Increasing Non-Latch	300	100	1000	290	1000	290	FS ¹
Carbon Monoxide (10)	Fine	◐	0-100	1	PPM	15	6.4	30	8.8	Increasing Non-Latch	60	15	1000	0-10	0-1000	5	FS ¹
Carbon Monoxide (11)	Fine	◑	0-500	1	PPM	50	5.6	150	8.8	Increasing Non-Latch	300	15	1000	0-10	0-1000	5	FS ¹
Carbon Monoxide (12)	Fine	◒	0-1000	1	PPM	100	5.6	300	8.8	Increasing Non-Latch	400	15	1000	0-10	0-1000	5	FS ¹
Carbon Monoxide H ₂ Resistant (14)	Fine	◑	0-100	1	PPM	15	6.4	30	8.8	Increasing Non-Latch	60	15	1000	0-10	0-1000	5	FS ¹
Carbon Monoxide (36)	Fine	●	0-100	1	PPM	15	6.4	30	8.8	Increasing Non-Latch	60	15	1000	0-10	0-1000	5	FS ¹
Carbon Monoxide (37)	Fine	●	0-500	1	PPM	50	5.6	150	8.8	Increasing Non-Latch	300	15	1000	0-10	0-1000	5	FS ¹
Carbon Monoxide (38)	Fine	●	0-1000	1	PPM	100	5.6	300	8.8	Increasing Non-Latch	400	15	1000	0-10	0-1000	5	FS ¹
Carbon Monoxide	Fine	●	0-100	1	PPM	15	6.4	30	8.8	Increasing Non-Latch	60	15	1000	0-10	0-1000	5	FS ¹

Gas (Code)	Thread Type ⁴	TruCal	Range Default	Display Resolution ₃	Unit Default	Alarm 1 Default	Alarm 1 Default AO (mA)	Alarm 2 Default	Alarm 2 Default AO (mA)	Alarm Action Default	Span Value Default	Alarm Min	Alarm Max	Range Min	Range Max	Span Value Min	Span Value Max
(39)																	
Catalytic Bead 5% Methane (60)	Fine	○	0-100	1	% LEL	10	5.6	30	8.8	Increasing Non-Latch	50	5	60	0-20 ²	0-100	10	100
Catalytic Bead 2.1% Propane (61)	Fine	○	0-100	1	% LEL	10	5.6	30	8.8	Increasing Non-Latch	29	5	60	0-20 ²	0-100	10	100
Catalytic Bead 1.05% Heptane (62)	Fine	○	0-100	1	% LEL	10	5.6	30	8.8	Increasing Non-Latch	45	5	60	0-20 ²	0-100	10	100
Catalytic Bead 0.8% Nonane (63)	Fine	○	0-100	1	% LEL	10	5.6	30	8.8	Increasing Non-Latch	61	5	60	0-20 ²	0-100	10	100
Catalytic Bead 4% Hydrogen (64)	Fine	○	0-100	1	% LEL	10	5.6	30	8.8	Increasing Non-Latch	20	5	60	0-20 ²	0-100	10	100
Catalytic Bead 4.4% Methane (65)	Fine	○	0-100	1	% LEL	10	5.6	30	8.8	Increasing Non-Latch	57	5	60	0-20 ²	0-100	10	100
Catalytic Bead	Fine	○	0-100	1	% LEL	10	5.6	30	8.8	Increasing Non-Latch	35	5	60	0-20 ²	0-100	10	100

Gas (Code)	Thread Type ⁴	TruCal	Range Default	Display Resolution ₃	Unit Default	Alarm 1 Default	Alarm 1 Default AO (mA)	Alarm 2 Default	Alarm 2 Default AO (mA)	Alarm Action Default	Span Value Default	Alarm Min	Alarm Max	Range Min	Range Max	Span Value Min	Span Value Max
1.7% Propane (66)																	
Catalytic Bead 0.85% Heptane (67)	Fine	○	0-100	1	% LEL	10	5.6	30	8.8	Increasing Non-Latch	56	5	60	0-20 ²	0-100	10	100
Catalytic Bead 0.7% Nonane (68)	Fine	○	0-100	1	% LEL	10	5.6	30	8.8	Increasing Non-Latch	70	5	60	0-20 ²	0-100	10	100
Chlorine (30)	Coarse	○	0-5	0.1	PPM	0.5	5.6	1.0	7.2	Increasing Non-Latch	2.0	0.3	5.0	0-1.0	0-5.0	0.1	FS ¹
Chlorine (31)	Coarse	○	0-10	0.1	PPM	0.5	4.8	1.0	5.6	Increasing Non-Latch	2.0	0.3	10.0	0-1.0	0-10.0	0.1	FS ¹
Chlorine (32)	Coarse	○	0-20	0.1	PPM	2.0	5.6	4.0	7.2	Increasing Non-Latch	10.0	0.6	20.0	0-1.0	0-20.0	0.1	FS ¹
Chlorine Dioxide (35)	Coarse	No	0-3 PPM	0.01	PPM	0.3	5.6	0.9	8.8	Increasing Non-Latch	0.1	0.1	3	0-0.5	3	0.5	FS ¹
Ethylene Oxide (71)	Coarse	No	0-10 PPM	0.1	PPM	1	5.6	2	7.2	Increasing Non-Latch	4	1	10	1	10	0.1	FS ¹
Hydrogen (70)	Fine	○	0-1000 PPM	10	PPM	50	4.8	100	5.6	Increasing Non-Latch	500	30	1000	250	0-1000	250	FS ¹
Hydrogen Chloride (74)	Coarse	○	0-10 PPM	1	PPM	5	5.6	10	7.2	Increasing Non-Latch	10	4	50	0-25	0-50	5	10

Gas (Code)	Thread Type ⁴	TruCal	Range Default	Display Resolution ₃	Unit Default	Alarm 1 Default	Alarm 1 Default AO (mA)	Alarm 2 Default	Alarm 2 Default AO (mA)	Alarm Action Default	Span Value Default	Alarm Min	Alarm Max	Range Min	Range Max	Span Value Min	Span Value Max
Hydrogen Cyanide (75)	Fine	○	0-50 PPM	1	PPM	5	5.6	10	7.2	Increasing Non-Latch	10	3	50	0-6	0-50	6	FS ¹
Hydrogen Flouride (76)	Coarse	No	0-10 PPM	0.1	PPM	1	5.6	2	7.2	Increasing Non-Latch	6	0.5	10	0-0.5	0-10	0.5	FS ¹
Hydrogen Sulfide (23)	Fine	○	0-500 PPM	1	PPM	50	5.6	100	7.2	Increasing Non-Latch	250	1	500	20	0-500	20	FS ¹
Hydrogen Sulfide (24, 77)	Fine	◐	0-20 PPM	0.1	PPM	6	4.8	12	6.4	Increasing Non-Latch	10	1	19	10	20	5	FS ¹
Hydrogen Sulfide (25, 78)	Fine	◑	0-50 PPM	0.1	PPM	15	8.8	30	8.8	Increasing Non-Latch	25	3	48	10	50	5	FS ¹
Hydrogen Sulfide (26, 79)	Fine	◒	0-100 PPM	0.1	PPM	30	8.8	60	8.8	Increasing Non-Latch	50	5	95	10	100	5	FS ¹
Hydrogen Sulfide (42, 80)	Fine	◓	0-20 PPM	0.1	PPM	6	8.8	12	13.6	Increasing Non-Latch	10	1	19	10	20	5	FS ¹
Hydrogen Sulfide (43, 81)	Fine	◔	0-50 PPM	0.1	PPM	15	8.8	30	13.6	Increasing Non-Latch	25	3	48	10	50	5	FS ¹
Hydrogen Sulfide (44, 82)	Fine	◕	0-100 PPM	0.1	PPM	30	8.8	60	13.6	Increasing Non-Latch	50	5	95	10	100	5	FS ¹
Hydrogen Sulfide (20, 83)	Fine	◖	0-10.0 PPM	0.1	PPM	1.0	5.6	3.0	8.8	Increasing Non-Latch	5.0	1.0	100	0-10	0-100	5	FS ¹

Gas (Code)	Thread Type ⁴	TruCal	Range Default	Display Resolution ₃	Unit Default	Alarm 1 Default	Alarm 1 Default AO (mA)	Alarm 2 Default	Alarm 2 Default AO (mA)	Alarm Action Default	Span Value Default	Alarm Min	Alarm Max	Range Min	Range Max	Span Value Min	Span Value Max
Hydrogen Sulfide (21, 84)	Fine	◐	0-50.0 PPM	0.1	PPM	5.0	5.6	15.0	8.8	Increasing Non-Latch	40.0	1.0	100	0-10	0-100	5	FS ¹
Hydrogen Sulfide (22, 85)	Fine	◐	0-100 PPM	0.1	PPM	10.0	5.6	30.0	8.8	Increasing Non-Latch	40.0	1.0	100	0-10	0-100	5	FS ¹
Hydrogen Sulfide (27, 86)	Fine	●	0-10.0 PPM	0.1	PPM	1.0	5.6	3.0	8.8	Increasing Non-Latch	5.0	1.0	100	0-10	0-100	5	FS ¹
Hydrogen Sulfide (28, 87)	Fine	●	0-50.0 PPM	0.1	PPM	5.0	5.6	15.0	8.8	Increasing Non-Latch	40.0	1.0	100	0-10	0-100	5	FS ¹
Hydrogen Sulfide (29, 88)	Fine	●	0-100 PPM	0.1	PPM	10.0	5.6	30.0	8.8	Increasing Non-Latch	40.0	1.0	100	0-10	0-100	5	FS ¹
Nitric Oxide (72)	Fine	○	0-100 PPM	0.5	PPM	10	5.6	20	7.2	Increasing Non-Latch	50	5	100	0-2.5	0-100	1	FS ¹
Nitrogen Dioxide (73)	Coarse	○	0-10 PPM	0.1	PPM	1	5.6	2	7.2	Increasing Non-Latch	5	0.5	10	0-1.5	0-10	1.5	FS ¹
Oxygen FM(15)	Fine	○	0-25%	0.1	%	19.5	16.48	18.0	15.5	Decreasing Non-Latch	20.8	17	24	5-25	15		
Oxygen (16)	Fine	○	0-25%	0.1	%	19.5	16.48	18.0	15.5	Decreasing Non-Latch	20.8	5.0	25.0	5.0-25	5.0-25	15	25
Low Oxygen (17)	Fine	○	0-25%	0.1	%	1	4.64	2	5.28	Increasing Non-Latch	20.8	0.2	25	0-2	0-25	20.8 (Room Air)	FS ¹
Sulfur Dioxide	Coarse	○	0-25 PPM	0.1	PPM	2.0	5.28	5.0	7.2	Increasing Non-Latch	10	0.4	25	0-5.0	0-25	2.5	25

Gas (Code)	Thread Type ⁴	TruCal	Range Default	Display Resolution ₃	Unit Default	Alarm 1 Default	Alarm 1 Default AO (mA)	Alarm 2 Default	Alarm 2 Default AO (mA)	Alarm Action Default	Span Value Default	Alarm Min	Alarm Max	Range Min	Range Max	Span Value Min	Span Value Max
(50)																	
Sulfur Dioxide (51)	Coarse	○	0-100 PPM	0.1	PPM	10	5.6	20	5.28	Increasing Non-Latch	10	2	100	0-10	0-100	7	FS ¹

¹ FS = Full Scale Range

² The Range Max value on catalytic bead cannot be set below 20%.

³ Display resolution is not a configurable option.

⁴ Class I Division 2/Zone 2 Only sensors do not have a flame arrestor (aka Frit). Coarse threads on the sensor assembly and sensor body are used to prevent a customer from installing into a Class I Division 1/Zone 1 sensor body.

○	TruCal not available
◐	Adaptive Environmental Compensation (AEC) Equipped
●	AEC and Diffusion Supervision Equipped

Table 15 Default Sensor Settings - XIR Plus Sensors

Gas (Code)	Range Default	Display Resolution ¹	Unit Default	Alarm 1 Default	Alarm 1 Default AO (mA)	Alarm 2 Default	Alarm 2 Default AO (mA)	Alarm Action Default	Span Value Default	Alarm Min	Alarm Max	Range Min	Range Max	Span Value Min	Span Value Max
XIR PLUS5% Methane (AA)	0-100	1	% LEL	10	5.6	20	7.2	Increasing Non-Latch	50	5	60	0-20	0-100	1	100
XIR PLUS4.4% Methane (AC)	0-100	1	% LEL	10	5.6	20	7.2	Increasing Non-Latch	57	5	60	0-20	0-100	1	100
XIR PLUS2.1% Propane (AB)	0-100	1	% LEL	10	5.6	20	7.2	Increasing Non-Latch	29	5	60	0-20	0-100	1	100
XIR PLUS1.7% Propane (AD)	0-100	1	% LEL	10	5.6	20	7.2	Increasing Non-Latch	35	5	60	0-20	0-100	1	100
XIR PLUS0 - 2.00% CO ₂ (AF)	0-2.00	0.02	%	0.20	5.6	0.40	7.2	Increasing Non-Latch	1.50	0.20	2.00	0-0.40	0-2.00	0.02	2.00
XIR PLUS0 - 5.00% CO ₂ (AG)	0-5.00	0.05	%	0.50	5.6	1.00	7.2	Increasing Non-Latch	2.50	0.50	5.00	0-1.00	0-5.00	0.05	5.00
XIR PLUS0 - 100% LEL Ethanol (BY)	0-100	1	% LEL	10	5.6	20	7.2	Increasing Non-Latch	35	5	60	0-20	0-100	1	100
XIR PLUS0 - 100% LEL Ethanol (CF)	0-100	1	% LEL	10	5.6	20	7.2	Increasing Non-Latch	65	5	60	0-20	0-100	1	100
XIR PLUS0 - 100% LEL Ethanol (CG)	0-100	1	% LEL	10	5.6	20	7.2	Increasing Non-Latch	41	5	60	0-20	0-100	1	100

Gas (Code)	Range Default	Display Resolution ¹	Unit Default	Alarm 1 Default	Alarm 1 Default AO (mA)	Alarm 2 Default	Alarm 2 Default AO (mA)	Alarm Action Default	Span Value Default	Alarm Min	Alarm Max	Range Min	Range Max	Span Value Min	Span Value Max
XIR PLUS0 - 100% LEL Ethanol (CP)	0-100	1	% LEL	10	5.6	20	7.2	Increasing Non-Latch	48	5	60	0-20	0-100	1	100
XIR PLUS0 - 100% LEL Methyl Methacrylate (DJ)	0-100	1	% LEL	10	5.6	20	7.2	Increasing Non-Latch	72	5	60	0-20	0-100	1	100
XIR PLUS0 - 100% LEL Ethanol ATEX (FJ)	0-100	1	% LEL	10	5.6	20	7.2	Increasing Non-Latch	37	5	60	0-20	0-100	1	100
XIR PLUS0 - 100% LEL Ethylene Oxide ATEX (FM)	0-100	1	% LEL	10	5.6	20	7.2	Increasing Non-Latch	75	5	60	0-20	0-100	1	100
XIR PLUS 0-100% LEL Gasoline Hexane ATEX (FN)	0-100	1	% LEL	10	5.6	20	7.2	Increasing Non-Latch	45	5	60	0-20	0-100	1	100
XIR PLUS 0-100% LEL Hexane (FP)	0-100	1	% LEL	10	5.6	20	7.2	Increasing Non-Latch	41	5	60	0-20	0-100	1	100

¹ Display resolution is not a configurable option.

4.3 Status Menu

The following settings can be viewed through Status Menu without a password, regardless of whether one is enabled.

1. Scroll and select Status.
2. Use ↓ to scroll through the list:
 - Tag #
 - Software Version
 - Input Voltage
 - Sensor Type
 - Life and Health
 - Previous Calibration Dates Alarm Setup
 - Alarm 1 Set Point
 - Alarm 1 Actions
 - Alarm 2 Set Point
 - Alarm 2 Actions
 - Relay Setup
 - Mapping Energy State
 - Bluetooth Tag ID
3. Use → to go back to the main menu.

4.3.1 Life and Health - XCell H₂S and CO Sensors with TruCal Only

The Life and Health information reports the general health of the sensor. XCell sensors with TruCal (Hydrogen Sulfide and Carbon Monoxide) calculate current sensor sensitivity using automated pulse checks. The pulse stimulates the sensor with a response similar to having actual calibration gas applied. The stimulated response is compared to the last calibration and will make adjustments to sensitivity to match the last calibration. When the required adjustment is greater than the accuracy of the algorithm's adjustment, the sensor will call for a calibration.

All digital sensors, including catalytic bead and oxygen, will show life health status as 'Good' or 'Fair' with the following calculation:



Good condition occurs when the current calibrated span sensitivity is greater than 50% of the way between the initial calibration sensitivity and the end-of-life span sensitivity. Fair condition occurs when the current calibrated span sensitivity is less than 50% of the way from the initial calibration sensitivity and the end of life span sensitivity.

NOTICE

Using expired calibration gas or the incorrect calibration gas can result in a premature "Fair" status.

5 Calibration

Calibration is the process of applying a known quantity of gas to the transmitter so that the transmitter can adjust the precision and accuracy of the measurements made in normal operating mode. This process ensures that gas measurements are as accurate as possible.

Calibration Warnings - Read before Calibrating

Although ULTIMA X5000 sensors are factory calibrated, another calibration is recommended once the unit is installed in its final environmental destination.

⚠ WARNING!

Use zero gas when zeroing the ULTIMA X5000 transmitter if there is any possibility of background gas. Otherwise, improper calibration could occur.

For optimal sensor performance, allow sensor to acclimate to application conditions for 24 hours before performing an initial calibration.

Perform calibrations 24 hours after initial start up and at a frequency identified in section [5.2 Calibration Frequency](#) and [5.3.1 Calibration Frequency for XCell Sensors with TruCal and Diffusion Supervision \(H2S & CO only\)](#).

XCell Sensors with TruCal (CO % H₂S) with Calibration Alert enabled provide an indication for "Calibration Recommended" and "Calibration Required". When either indication is provided by the device, calibrate the sensor.

Failure to follow this warning can result in serious personal injury or death.

5.1 Calibration Equipment

A gas cylinder with a known concentration of gas appropriate for the range of measurement is needed. Sensors come with preset span gas values appropriate for the measurement range. See [Table 14](#) for Default Span Values by Sensor Type. Calibration kits are available from MSA for calibration of the ULTIMA X5000. The kits come housed in a convenient carrying case and contain all items necessary for a complete and accurate calibration, including a regulator, tubing, and calibration caps. See [Table 16](#) to select the appropriate kit for the sensor type. The calibration kit can also be ordered without a gas cylinder.

Table 16 Calibration Kits

Gas Type	Range	Concentration	Cylinder P/N	P/N with Calibration Kit	Calibration Kit Only (No Cylinder)
Carbon Monoxide	0-100 PPM	60 PPM ¹	710882	710882-KIT1	CALKIT1
	0-500 PPM	300 PPM ¹	10027938	10027938-KIT1	CALKIT1
	0-1000 PPM	400 PPM ¹	10028048	10028048-KIT1	CALKIT1
Hydrogen	0-1000 PPM	500 PPM ²	10022386	19922386-KIT1	CALKIT1
Hydrogen Sulfide	0-10 PPM	5 PPM ²	10028084	10028084-KIT1	CALKIT1
	0-50 PPM	40 PPM ²	10028062	10028062-KIT1	CALKIT1
	0-100 PPM				
	0-20 PPM	10 PPM ¹	1400255-1	1400250-1	N/A
	0-50 PPM	25 PPM ¹	1400255-3	1400250-3	
	0-100 PPM	50 PPM ¹	1400255-5	1400255-5 1400250-5	
	0-500 PPM	250 PPM ²	10089547	10089547-KIT1	CALKIT1
Oxygen	0-25 %	20.8 % ²	10028028	10028028-KIT1	CALKIT1
	0-25 %	5 % Oxygen ²	10028036	10028036-KIT1	CALKIT1
Sulfur Dioxide	0-25 PPM	10 PPM ¹	10028070	10028070-KIT2	CALKIT2
	0-100 PPM	10 PPM ¹	10028070	10028070-KIT1	CALKIT1
Chlorine	0-5 PPM	2 PPM ²	710331	710331-KIT1	CALKIT1
	0-10 PPM				
	0-20 PPM	10 PPM ²	10028066	10028066-KIT1	CALKIT1
Nitric Oxide	0-100 PPM	50 PPM ²	10028074	10028074-KIT1	CALKIT1

Gas Type	Range	Concentration	Cylinder P/N	P/N with Calibration Kit	Calibration Kit Only (No Cylinder)
Hydrogen Fluoride ⁴	0-10 PPM	10 PPM ²	10053747	10053747-KIT3	CALKIT3
Ethylene Oxide	0-10 PPM	4 PPM ²	10221123	10221123-KIT3	CALKIT3
Chlorine Dioxide ⁵	0-3 PPM	10 PPM ¹	10028068	10028068-KIT1	CALKIT1
Hydrogen Cyanide	0-50 PPM	10 PPM ²	10028072	10028072-KIT1	CALKIT1
Hydrogen Chloride	0-50 PPM	10 PPM ²	10053747	10053747-KIT3	CALKIT3
Nitrogen Dioxide	0-10 PPM	5 PPM ¹	10028082	10028082-KIT2	CALKIT2
Ammonia	0-100 PPM	25 PPM ²	10028076	10028076-KIT1	CALKIT1
	0-1000 PPM	300 PPM ²	10044014	10044014-KIT1	CALKIT1
Combustible (XIR PLUS or Cat Bead)	0-100 % LEL 5 % Methane	2.5 % Methane (50 % LEL) ¹	10028032	10028032-KIT1	CALKIT1
	0-100 % LEL 4 % Methane	2.5 % Methane (57 % LEL) ¹			
	0-100 % LEL 2.1 % Propane	0.6 % Propane (29 % LEL) ¹	10028034	10028034-KIT1	CALKIT1
	0-100 % LEL 1.7 % Propane	0.6 % Propane (35 % LEL) ¹			
XIR PLUS CO ₂	0-2 %	1.50 % ²	10179972	10179972-KIT1	CALKIT1
	0-5 %	2.50 % ¹	10028024	10028024-KIT1	CALKIT1
Combustible (Catalytic Bead)	0-100 % LEL 4 % Hydrogen	0.8 % Hydrogen (20 % LEL) ¹	10028046	10028046-KIT1	CALKIT1
	0-100 % LEL 1.05 % Heptane	0.6 % Propane (45 % LEL) ¹	10028034	10028034-KIT1	CALKIT1
	0-100 % LEL 0.85 % Heptane (ATEX)	0.6 % Propane (56 % LEL) ¹			
	0-100 % LEL 0.8 % Nonane	0.6 % Propane (61 % LEL) ¹			

5 Calibration

Gas Type	Range	Concentration	Cylinder P/N	P/N with Calibration Kit	Calibration Kit Only (No Cylinder)
	0-100 % LEL 0.8 % Nonane (ATEX)	0.6 % Propane (71 % LEL) ¹			

¹ Balance Air

² Balance Nitrogen

⁴ Hydrogen Fluoride sensor calibrated with 10 PPM HCL and span value of 6 PPM

⁵ Chlorine Dioxide sensor calibration with 10 PPM NO₂ and a span value of 1.4 PPM

Flow Rates:

CALKIT1 = 1 liter/min

CALKIT2 = 0.25 liter/min

CALKIT3 = 0.5 liter/min, SST Regulator, used with HCL

CALKIT4 = Demand Regulator, used with sampling systems

5.2 Calibration Frequency

The frequency of calibration gas testing depends on the operating time, chemical exposure, and type of sensor. Especially in new installations or applications, it is recommended that the first sensors be calibrated more often to establish the sensor performance in this particular environment.

For this, you typically record the "as found" and "as left" gas values and track the percent adjustment over time. Then, gradually extend calibration intervals until the percent adjustment is greater than the expected accuracy of the sensor.

5.3 Calibration Frequency for XCell Sensors with TruCal (H₂S & CO only)

WARNING!

Certain conditions may prevent the performance of Diffusion Supervision and/or TruCal testing. If such a condition persists for 90 days, the XCell sensor with TruCal will recommend a calibration which is communicated through the transmitter display and LEDs. When Calibration Alert is enabled, the milliamp signal output will also be driven to calibration alert output. Perform a calibration when the device recommends it.

Failure to follow this warning can result in serious personal injury or death.

5.3.1 Calibration Frequency for XCell Sensors with TruCal and Diffusion Supervision (H₂S & CO only)

Sensors with TruCal technology will adjust sensitivity without any manual intervention or calibration, unless called for by the sensor. If the adjusted sensitivity from TruCal deviates too far from the last gas calibration sensitivity, the sensor will recommend or, in extreme cases, require a calibration. When a calibration is recommended, the transmitter LED status indicators slowly pulse green. Users can also enable a Calibration Alert function that will send a milli-amp signal on the analog output to the control room when a calibration is recommended. When a calibration is required, the status LEDs will flash yellow and the transmitter will go into a Calibration Required Fault. With Diffusion Supervision enabled, the sensors also actively monitor the sensor inlet for obstructions and initiates a fault if the gas diffusion path becomes obstructed.

With Diffusion Supervision and Calibration Alert enabled, the time between scheduled calibrations can be extended to 24 months.

If calibration and/or Diffusion Supervision are disabled, follow the calibration frequency recommendations set forth in [5.3.2 Calibration Frequency for XCell Sensors with TruCal without Diffusion Supervision \(H₂S & CO only\)](#).

5.3.2 Calibration Frequency for XCell Sensors with TruCal without Diffusion Supervision (H₂S & CO only)

Sensors with TruCal technology will adjust sensitivity without any manual intervention or calibration, unless called for by the sensor. If the adjusted sensitivity from TruCal deviates too far from the last gas calibration sensitivity, the sensor will recommend or, in extreme cases, require a calibration. When a calibration is recommended, the transmitter LED status indicators slowly pulse green. Users can also enable a Calibration Alert function that will send a milli-amp signal on the analog output to the control room when a calibration is recommended. When a calibration is required, the status LEDs will flash yellow and the transmitter will go into a Calibration Required Fault. Without Diffusion Supervision, regular calibration of the sensor must still be conducted to confirm the sensor inlet is not obstructed.

Actual TruCal sensor performance will depend on the application, background gas exposure, and environment. To validate XCell sensors with TruCal, it is recommended that users follow their regular calibration cycle and record the “as found” and “as left” values, tracking the percent adjustment over time. Once a baseline is established, the calibration intervals can be extended until the percent adjustment is greater than the expected accuracy of the sensor.

5.4 Calibration Types: Zero vs. Span

The ULTIMA X5000 has two types of calibration: Zero and Span calibration.

Zero Calibration resets the baseline level reading to zero. If the target gas is suspected to be occasionally present, it is best to also use a zero gas cylinder during the zero calibration. If the target gas is not present in the atmosphere, an additional calibration cylinder is not required.

The "Calibrate" option involves first applying a zero gas followed by the span gas. The span gas is a known concentration of gas which adjusts the accuracy and precision of the transmitter to the known value; this is referred to as the “Span Value.” See [Figure 41](#).

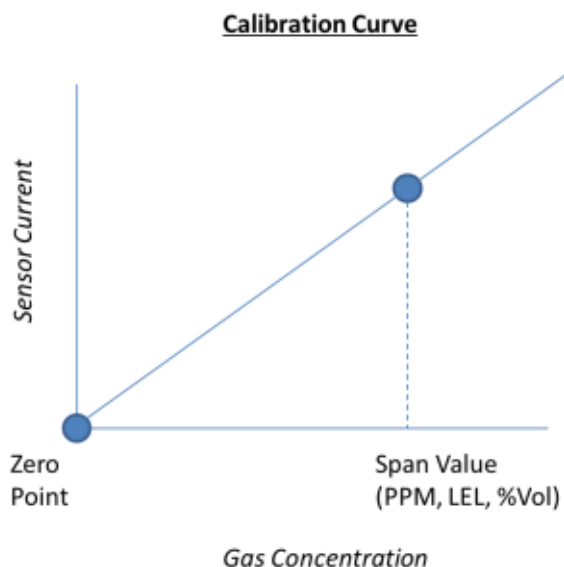

Figure 41 Calibration Curve

The Sensor Span Value in the device menu should be the same as the concentration listed on the calibration gas cylinder; unless an LEL simulant gas is being used.

The XIR PLUS sensor can be calibrated to a wide variety of gas compounds using either 0.1 % Propane, 0.6 % Propane, or 2.5 % Methane and MSA's gas table. See [Table 20](#) for a complete list of gas compounds and corresponding tables and span values.

5.5 How to Zero Calibrate XCell Sensors

NOTICE

If a password is enabled, you will not be able to proceed with the calibration without the password.

5 Calibration

To abort, press either button on the touchscreen or mobile application at any time during the zero calibration.



In the event that a calibration cannot be completed, the user can acknowledge the FAIL by placing one finger over each of the EZ touch buttons and holding for 1 second before releasing. The unit will revert to the settings of the last successful calibration.

WARNING!

The regulator used with the zero gas cylinder should not be the same as the regulator used for the span gas. The span gas regulator can be contaminated with the target gas over time, and thus raise the detection baseline and make the sensor less sensitive to the target gas.

Failure to follow this warning can result in serious personal injury or death.



If there is no target gas in the atmosphere around the sensor, using a zero gas cylinder is optional.

To Zero calibrate the sensor,

1. Attach the Sensor Guard to the bottom of the sensor.
 2. Place the green Calibration Cap over the Sensor Guard inlet so that it is flush with the bottom of the Sensor Guard and completely covers the Sensor Guard inlet.
 3. Attach the tubing to the plastic stem protruding through the green Calibration Cap.
 4. Screw the regulator onto the top of the zero gas cylinder.
-



If a password is enabled, you will need to enter it here.

NOTICE

If the calibration cap cannot be used (such as for a remote sensor application), ambient wind conditions must be minimized during calibration to avoid a calibration with increased sensitivity.

5. Scroll and select Calibration.
6. Scroll and select *Zero Calibration*.
7. Once the screen displays Zero Soaking, turn on zero gas flow by turning knob on the regulator.
8. Wait while the device displays the countdown of the Zero Calibration.
9. Once the zero calibration is complete, a Zero PASS or FAIL is displayed.

If PASS displays, the procedure is complete. User may record the as found and as left values as an indication of the amount of sensor correction performed during the calibration.

If FAIL displays, the procedure was unsuccessful.

10. Remove the zero calibration equipment from the device, including the Sensor Guard and Calibration Cap.
-



Sensors with TruCal and have Diffusion Supervision enabled can go into Diffusion Supervision Fault if the green calibration cap is left on after completing a zero calibration.

WARNING!

The green calibration cap must be removed from the sensor after a zero calibration. Failure to do so could restrict gas flow to the sensor and result in erroneously low readings.

Failure to follow this warning can result in serious personal injury or death.

5.6 How to Calibrate XCell Sensors

(See [5.7 How to Calibrate an Oxygen XCell Sensor](#) for calibrating oxygen sensors.)

NOTICE

If a password is enabled, the user will not be able to proceed with the calibration without the password.

To abort, press either button on the touchscreen or mobile application before Span Calibration begins.



In the event that a calibration cannot be completed, the user can acknowledge the FAIL by placing one finger over each of the EZ touch buttons and holding for 1 second before releasing. The device will revert to the settings of the last successful calibration.

1. Attach a regulator to the zero gas cylinder (if using) and the calibration cylinder.
2. Attach the sensor guard to the bottom of the sensor.
3. Place the green calibration cap over the sensor guard inlet so that it is flush with the bottom of the sensor guard and completely covers the sensor guard inlet.
4. Attach the tubing to the plastic stem protruding through the green calibration cap.
5. Push the other end of the tubing over the zero cylinder regulator. Ensure the tubing completely covers the gas outlet.
6. Scroll and select Calibration.



If a password is enabled, you will need to enter it here.

NOTICE

If the calibration cap cannot be used (such as for a remote sensor application), ambient wind conditions must be minimized during calibration to avoid a calibration with increased sensitivity.

7. Select Sensor #1 or Sensor #2.
8. Once the screen displays Zero Soaking, turn on zero gas flow by turning knob on the regulator.
9. Wait while the device displays the countdown of the Zero Calibration.
10. Once the zero calibration is complete, remove the tubing from the sensor guard inlet.
11. Attach tubing for calibration gas and turn on the regulator

Display will show "Span in Progress".

"Remove Gas" will show when span is complete.

If PASS displays, the procedure is complete. User may record the as found and as left values as an indication of the amount of sensor correction performed during the calibration.

If FAIL displays, the procedure was unsuccessful.

12. Remove the calibration equipment from the device, including the sensor guard and calibration cap.



Sensors with TruCal and have Diffusion Supervision enabled can go into Diffusion Supervision Fault if the green calibration cap is left on after completing a calibration.

WARNING!

The green calibration cap must be removed from the sensor after calibration. Failure to do so could restrict gas flow to the sensor and result in erroneously low readings.

Failure to follow this warning can result in serious personal injury or death.

5.7 How to Calibrate an Oxygen XCell Sensor

An oxygen span gas cylinder is not needed if the sensor is in an area that maintains ambient air conditions. Follow the same process for XCell sensors as described in [5.8 How to Calibrate an XIR PLUS Sensor](#). When the display prompts "Apply Span Gas", simply allow the countdown to occur without applying gas.

If the sensor is located in an area of normally low or enriched oxygen, then a 20.8% oxygen sample must be applied.

5.8 How to Calibrate an XIR PLUS Sensor

A full span calibration is not required for the XIR PLUS sensors. Any degradation of the sensor's performance is associated with slight drifts in its zero response. Restoring the sensor's zero is typically sufficient.

The XIR PLUS sensor guard comes attached to the XIR PLUS sensor. The XIR PLUS calibration cap is placed over the sensor guard so that it is completely covered. Line up the cap so that the sensor guard stem protrudes through the calibration cap. Zero or calibration gas tubing is then attached to the sensor guard via the stem.

WARNING!

The green calibration cap must be removed from the XIR PLUS after calibration. Failure to do so could restrict gas flow to the sensor and result in erroneously low readings.

Failure to follow this warning can result in serious personal injury or death.

NOTICE

If the calibration cap cannot be used (such as for a remote sensor application), ambient wind conditions must be minimized during calibration to avoid a calibration with increased sensitivity.

The XIR PLUS sensor can be calibrated to a variety of other target gases. Calibrating to a different calibration gas will align the sensor's accuracy to that gas. Refer to [9 Appendix: Calibration Guide for Additional Gases](#) for calibration settings. Note that the XIR PLUS sensor is a general hydrocarbon sensor, and calibrating to another gas will not prevent it from seeing other hydrocarbons in the atmosphere.

5.9 XCell Catalytic Bead LOC Over Range

Catalytic bead sensors require the presence of oxygen in order to sense combustible gas. In the event of very large combustible gas leaks that exceed 100 % LEL, enough oxygen can be displaced so that the sensor's response to gas is no longer proportional to the calibration profile. The XCell catalytic bead has a locking fail safe mechanism that prevents the false reporting of a safe condition while the % LEL concentration is still above 100 % LEL. When the gas concentration exceeds 100 % LEL, the sensor will go into LOC over range.

To clear the LOC over range, the user needs to acknowledge and calibrate the sensor. To acknowledge LOC over range, place one finger over each of the EZ touch buttons and hold for 1 second before releasing. This will allow a recalibration of the sensor to clear the LOC condition.

WARNING!

Ensure that the area has been cleared of gas before acknowledging the LOC Over Range and recalibrating the sensor.

Failure to follow this warning can result in serious personal injury or death.

5.10 Calibration Confirmation and As Found/As Left Values

The ULTIMA X5000 Gas Monitor records the date of the last successful calibration as well as the As Found/As Left values. This date can then be displayed on the OLED display under the Status Menu.

6 Maintenance

WARNING!

Use only genuine MSA replacement parts when performing any maintenance procedures provided in this manual. Failure to do so may seriously impair sensor and gas monitoring performance, alter flameproof/explosionproof characteristics or void agency approvals. Failure to follow this warning could cause the product to fail to perform as designed and persons who rely on this product for their safety could sustain serious personal injury or loss of life.

Repair or alteration of the ULTIMA X5000 Gas Monitor, beyond the scope of the maintenance procedures provided in this manual or by anyone other than authorized MSA service personnel, could cause the product to fail to perform as designed and persons who rely on this product for their safety could sustain serious personal injury or loss of life.

The ULTIMA X5000 Gas Monitor is constantly performing a self-check. When a problem is found, it displays the appropriate error message. When a critical error is detected within the device, the 4-20 mA output signal goes to a fault condition.

6.1 ULTIMA XIR PLUS Cleaning Procedure

The presence of particulate matter, oil films, liquid water, or the residue from water drops on the two monitor windows can adversely affect its performance. The XIR PLUS sensor guard is designed to prevent foreign solids or liquids from reaching the monitor's optical system. Additionally, heating elements are incorporated into the device to prevent water condensation. Under severe conditions, however, some material may collect on these surfaces and it may be necessary to occasionally check and clean the windows.

While both windows are made of a highly durable material that is not easily scratched, avoid excessive pressure when cleaning them. Clean, cotton-tipped applicators are the most convenient tool to remove material collected on the windows.

- Use a dry applicator or one moistened with distilled water to wipe the window and remove dust.
- Use an additional clean, dry applicator to remove any residual water.
- Use an applicator moistened with isopropyl alcohol to remove heavy deposits of solids, liquids or oil films. Clean the window again with a second applicator moistened with distilled water; then, dry the window with a final applicator.
- Avoid using excessive amounts of water or alcohol in the cleaning procedure, and inspect the window to ensure that the entire surface is clean.
- The device will go into a "Low Signal" fault during cleaning with an analog output to 2.0 mA.

To clean the XIR PLUS sensor:

1. Remove the Sensor Guard.
2. Place an opaque object (piece of paper, cardboard, etc.) between the light source window and the mirror to completely obscure the light path for two to three seconds.

The ULTIMA X5000 analog output is in a fault condition while sensor is partially blocked.

The display will indicate "Low Signal".



While in "Low Signal" fault, the sensor will not respond to the presence of gas.

3. When cleaning is done and the objects are removed from the sensor window, the device returns to normal operation. If water or isopropyl alcohol was used, allow the device to operate for 15 minutes to completely dry before replacing the sensor guard and continuing to monitor for combustible gas.
4. Replace the sensor guard or flow cap.



When the cleaning process is complete, be sure to remove all objects from the light path. It is recommended to check the sensor's response to zero and calibration gas after cleaning.



Using other cleaning solutions or not thoroughly removing the isopropyl alcohol with a damp cloth may result in a gas reading from the hydrocarbon bonds of the solvent.

WARNING!

Do not place foreign objects in the sensor's analytical region (except for the "ULTIMA XIR PLUS Cleaning Procedure" as described above); otherwise, the infrared beam can be partially blocked, causing the sensor to generate false readings. All objects must be removed from the sensor's analytical region for it to function properly.

Failure to follow this warning can result in serious personal injury or death.

6.2 Replacing an XCell Sensor

The only routine maintenance item is the sensor, which has a limited lifetime. The ULTIMA X5000 sensors with TruCal technology will indicate when the sensor is near end of life through the Status Menu. When the Sensor Life & Health status is "Fair", you have approximately 2 months to replace the sensor before it will no longer function. When a TruCal sensor is no longer capable of sensing it will go into fault and LEDs will flash yellow. It is good practice to obtain a replacement sensing element before the sensing element within your unit becomes inoperative.

There is no need to open the main enclosure. Simply unscrew the digital sensor assembly from the sensor body assembly.

WARNING!

- Do not disassemble the sensor assembly. The sensing element inside may contain hazardous material.
- Handle the sensor carefully; the electrochemical version is a sealed unit which contains a corrosive electrolyte.
- Any leaked electrolyte that comes in contact with skin, eyes or clothes can cause burns.
- If any contact with the electrolyte does occur, immediately rinse with a large quantity of water. On contact with the eyes, rinse thoroughly with water for 15 minutes and consult a doctor.
- Do not install a leaking sensor in the sensing head assembly. The leaking sensor must be disposed of in accordance with local, state and federal laws.
- As part of the product certification, it was verified that optional communication functions of this gas detection instrument while operating at the maximum transaction rate do not adversely affect the gas detection operation and functions of the instrument. The product certification, however, does not include or imply approval of the SafeSwap feature, communications protocol or functions provided by the software of this instrument or of the communications apparatus and software connected to this instrument.
- Follow the warnings below when removing or replacing sensors. Reference [2.10](#) for component overview.
 - Never remove or replace a Sensor Body Assembly or an Ultima XIR Plus while under power or when explosive hazards are present.
 - Confirm that the area is free of explosive hazards before removing or replacing an XCell Sensor under power.
 - To remove an XCell Sensor, unscrew XCell Sensor three full turns, wait 10 seconds, and then remove the XCell Sensor completely.

Failure to follow this warning can result in serious personal injury or death.

Identify the sensor assembly needed via the A-5K-SENS code on the interior sensor label and obtain the appropriate sensor assembly. Screw the replacement XCell sensor onto the Sensor Body Assembly, ensuring that the XCell sensor mates flush against the bottom edge of the Sensor Body Assembly.

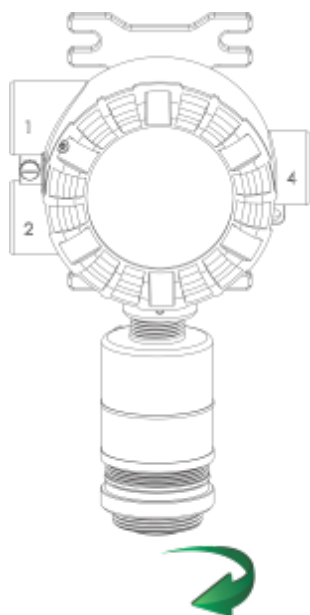

Figure 42 Removing the XCell Sensor

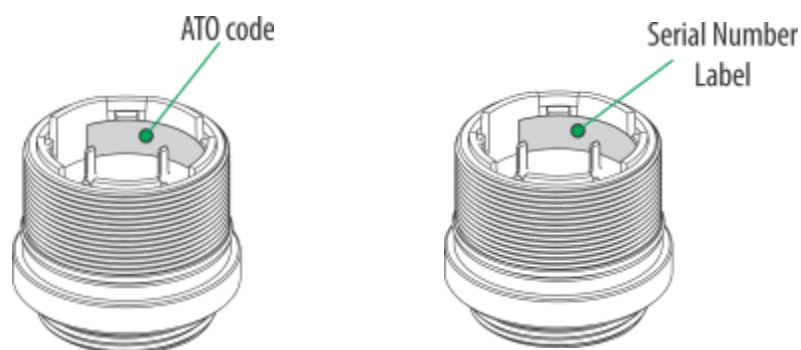

Figure 43 Digital Sensor - Position of Labels



Alarm set points, span value, full scale limit and alarm direction will not change when replacing a sensor with the same gas and range. Alarm set points, span value, full scale limit and alarm direction will change to the new sensor settings when replacing a sensor with a different gas and/or range.

The ULTIMA X5000 Gas Monitor is shipped with the Sensor Swap Delay enabled. This means that the 4-20 mA output signal and the FAULT relay will hold off a fault indication for two minutes before the missing sensor indication is displayed on the device. This setting allows the operator to exchange sensor modules without a FAULT indication. See Swap Delay in [4.2.1 Instrument Settings](#) for more details.



It is recommended that all other maintenance be performed at an MSA factory-authorized service center.

6.3 Clearing a Blockage

If using a Digital Sensor with Diffusion Supervision, and if the Diffusion Supervision feature has been enabled in the Sensor Settings, the sensor will notify the user if it detects foreign material obstructing the sintered metal frit where gas would normally enter the sensor (see [Figure 43](#)). When this condition is detected, the transmitter will go into fault and show “Diffusion Supervision Fault” on the display. Follow these recommended steps to attempt to clear this fault:

1. Inspect and clear the sensor inlet and frit.
2. Inspect and clear any accessories attached to the sensor.
3. Ensure Sensor is fully mated to the Sensor Body Assembly.
4. Attempt to recalibrate the Sensor.
5. Disable Diffusion Supervision or replace the Sensor.

6 Maintenance

First, with the sensor still installed, visually inspect the sensor to see if any objects are covering the gas inlet and remove them. Example objects may include tape or the green Calibration Cap. Next, check to make sure that there is no foreign material stuck to the frit. If any material is found, gently remove it while considering any hazards that may arise from such an action, like the accumulation of a static charge, and taking the necessary steps to avoid them. Take care to ensure that the frit is not damaged during the cleaning process. DO NOT use water or liquids to try to clean the frit. The frit acts like a sponge and will retain liquids, which will keep the gas path blocked.

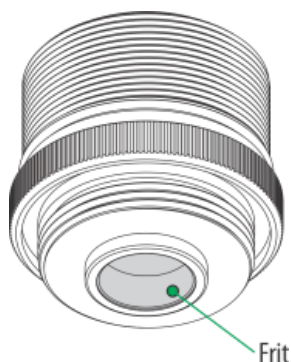

Figure 44 Frit Location

⚠ WARNING!

The sensor relies on the frit as a part of its Flameproof/Explosion proof approval. If the frit is damaged while attempting to clean it, immediately remove power from the device. Ensure the area is free of a hazardous atmosphere, then follow all steps as outlined in 6.2 to properly replace the sensor.

Failure to follow this warning can result in serious personal injury or death.

If no material is visible, the frit may still be blocked by a liquid which has absorbed into the frit. Once absorbed, liquids are very difficult to remove. For these situations, relying on natural evaporation is recommended. Due to the time it can take for liquids to evaporate sufficiently from the frit, users may want to consider swapping out the affected sensor with one that is known to be clear. Placing absorbent material against the outer surface of the frit can help accelerate this process.

If a sensor is in Diffusion Supervision Fault, the device will still allow the user to attempt to calibrate the sensor. In the rare event that a sensor calibration is successful, but the Diffusion Supervision system continues to detect a blockage in the gas path, the Diffusion Supervision Fault will return in approximately 24 hours. In this scenario, there is likely an environmental factor affecting the Diffusion Supervision detection. Provided the sensor can successfully calibrate, the sensor is still capable of detecting gas. To prevent the Diffusion Supervision Fault from reoccurring, a user can either disable Diffusion Supervision in the Sensor Settings (see 4.2.2 Sensor Settings) or replace the sensor.

6.4 Troubleshooting

The following table lists all fault messages, their priority levels, and corrective actions required to resolve them. The faults are listed in alphabetical order. Lower priority messages are output only after the highest priority message is cleared.

Table 17 Troubleshooting

Priority ¹	Display Message	Status LEDs (G/Y/R)	Latch Condition	Description	Resolution
35	“ACT Fault”	ON/ON/OFF	Latch	Indicates an out of range measurement	Replace the sensor.
24	“Beads Off Fault”	ON/ON/OFF	Latch	Indicates that the combustible sensors beads are OFF.	Acknowledge or cycle power to the sensor. Let the sensor warmup, then recalibrate the sensor. If this does not resolve the issue,

Priority ¹	Display Message	Status LEDs (G/Y/R)	Latch Condition	Description	Resolution
					replace the sensor.
23	“Calibration Required”	ON/ON/OFF	Latch	Indicates the sensor requires calibration.	Calibrate the sensor(s) attached to the instrument.
25	“Channel Error”	ON/ON/OFF	Latch	Indicates that there is an error in the mA output system.	Reset the sensor. Verify sensor configurations (if different from default values). Then recalibrate the sensor. IF this does not resolve the issue, replace the sensor. Check the mA output system on the main pcb.
7	“Configuration Fault”	ON/ON/OFF	Latch	Indicates that an incorrect configuration was detected.	Typically this is a unit with both sensors disabled and no sensor attached. Attach one sensor to the unit.
16	"Diffusion Supervision Fault"	ON/ON/OFF	Non-Latch	Indicates the sensor has detected a blockage in the gas path.	Refer to section 6.3 .
4	“EEPROM Fault”	ON/ON/OFF	Latch	Indicates there is an error with the EEPROM.	Select Controller Data Reset t from Instrument menu. Verify the customer settings. Replace the main PCBA.
29	“External Memory Access Error”	ON/ON/OFF	Latch	Indicates that an error occurred communicating to the EEPROM.	Select Reset Main Unit from Instrument menu. Verify the customer settings. Replace the main PCBA
30	“External Memory Checksum Error”	ON/ON/OFF	Latch	Indicates the EEPROM memory is not valid.	Select Controller Data Reset from Instrument menu. Verify any custom settings and re calibrate the instrument.
3	“Flash Checksum Fault”	ON/ON/OFF	Latch	Indicates there is something incorrect with the main PCBA's program.	Replace the main PCBA.
8	“General System Error”	ON/ON/OFF	Non-Latch	Indicates one of the internal power supplies is out of	Adjust the input power supply voltage to within range for the sensor

Priority ¹	Display Message	Status LEDs (G/Y/R)	Latch Condition	Description	Resolution
				range.	configuration. Replace the main PCBA.
5	"Internal Circuit Fault"	ON/ON/OFF	Latch	Indicates a hardware failure on the main PCBA.	Replace the main PCBA.
33	"Lamp Fault"	ON/ON/OFF	Latch	Indicates the sensors lamp is not operating properly. (XIR PLUS sensors only)	Replace the sensor.
15	"Life and Health Fault"	ON/ON/OFF	Latch	Indicates the sensor is at the end of life.	Recalibrate the sensor to get additional life. If error does not clear after recalibration, replace the sensor.
36	"Low Signal Failure"	ON/ON/OFF	Non-Latch	This indicates the sensors output is low.	Clean the optics on the sensor or replace the sensor.
17	"Negative Drift"	ON/ON/OFF	Latch	This indicates the sensor is reading downscale.	Recalibrate the sensor.
26	"Negative Supply Fault"	ON/ON/OFF	Non-Latch	Indicates the negative power supply is out of range.	Check the input power supply. If this is within range, then replace the sensor.
N/A	"Over Range"	ON/ON/OFF	Non-Latch	An over scale gas reading is present.	Verify the area is clear of gas first then recalibrate the sensor.
31	"Parameter out of range"	ON/ON/OFF	Latch	Indicates that a setting is improperly set in the unit.	Select Control Data Reset from Instrument menu. Verify any customer settings. Then recalibrate the sensor.
2	"RAM Checksum Fault"	ON/ON/OFF	Latch	Indicates a bad RAM memory location was detected.	Replace the main PCBA.
34	"Reference Failure"	ON/ON/OFF	Latch	Indicates an out of range measurement.	Replace the sensor.
6	"Relay Fault"	ON/ON/OFF	Latch	Indicates that a problem with the relays was detected.	Replace the relay options PCBA.
22	"Sensor Configuration Reset"	ON/ON/OFF	Latch	Indicates the sensor datasheet was reset.	Calibrate the sensor.

Priority ¹	Display Message	Status LEDs (G/Y/R)	Latch Condition	Description	Resolution
12	“Sensor Element Error”	N/A	Latch	Indicates the sensor is broken.	Replace the sensor.
38	“Sensor End of Life Fault”	ON/ON/OFF	Latch	Indicates the sensor is at the end of life.	Recalibrate the sensor/replace the sensor.
27	“Sensor FLASH Error”	ON/ON/OFF	Latch	Indicates there is something wrong with the sensors program.	Replace the sensor.
13	“Sensor Heater Fault”	ON/ON/OFF	Latch	Indicates the sensors heater is not working properly.	Replace the sensor.
25-40	“Sensor Internal Fault”	ON/ON/OFF	Latch	Indicates the detection of a hardware issue in the sensor.	Replace the sensor.
9	“Sensor Missing”	ON/ON/OFF	Non-Latch	Indicates the sensor is no longer detected.	Replace the sensor.
28	“Sensor RAM Error”	ON/ON/OFF	Latch	Indicates a bad RAM memory location was detected.	Replace the sensor.
10	“Sensor Supply Voltage Fault”	ON/ON/OFF	Non-Latch	Indicates the sensors input voltage is out of range.	Check the input power supply voltage and check the wiring to the sensor module for damage. If this does not resolve the issue, replace the sensor.
20	“Span Calibration Fault”	ON/ON/OFF	Latch	Indicates the sensor did not pass the Span calibration operation.	Acknowledge the fault by pressing and holding both EZ touch buttons at the same time for up to 5 seconds. The unit will revert to the previous calibration so that the unit can continue to detect gas while troubleshooting fault. Causes for this fault include: <ol style="list-style-type: none"> 1. Span gas is not applied within the calibration time-out period 2. The incorrect

Priority ¹	Display Message	Status LEDs (G/Y/R)	Latch Condition	Description	Resolution
					<p>span gas is applied or the span value is not set correctly in the Sensor Settings.</p> <p>3. The sensor is at its end of life.</p> <p>Check the span gas concentration and the sensor span value setting to ensure that the correct span gas is being used. Go through the calibration process again after verifying. If fault persists, replace the sensor.</p>
1	"Supply Voltage Fault"	ON/ON/OFF	Non-Latch	The input power supply is out of the operating range. It may be too low or too high.	Check the input power supply is within range for the sensor configuration.
14	"TEDS CRC-16 Error"	ON/ON/OFF	Latch	Indicates the sensors datasheet is invalid.	Reset the sensor. Verify the sensor settings (if different from default), then recalibrate the sensor.
40	"Unknown Error"	ON/ON/OFF	N/A	Indicates that a sensor is returning an unknown error condition.	Replace the sensor or update the main PCBA software.
19	"Zero Calibration Fault"	ON/ON/OFF	Latch	Indicates the sensor did not pass the Zero calibration operation.	<p>Acknowledge the fault to revert to the previous calibration. This fault can be caused by</p> <ol style="list-style-type: none"> 1. A bad sensor 2. The sensor is trying to zero while span gas is being applied. <p>Check the zero gas cylinder is correct and within expiration date. If not using zero gas, ensure that there is not a background concentration of the</p>

Priority ¹	Display Message	Status LEDs (G/Y/R)	Latch Condition	Description	Resolution
					target gas in the atmosphere. Go through the calibration process again after verifying. If fault persists, replace the sensor.
N/A	Full scale value and "LOC" displayed on the lower display areas per each sensor	ON/ON/OFF	Latch	Indicates a combustible sensors over range condition was measured.	Acknowledge the sensor, wait for the warmup time period and recalibrate the sensor.
N/A	Gas value is still shown.	Both side green LEDs blinking	N/A	Indicates that calibration is recommended. (TruCal sensors only)	Calibrate the sensors attached to the unit.
11	Parameter Fault (Sensor)	ON/ON/OFF	Latch	Indicates that a setting is improperly set in the unit.	Reset the sensors datasheets. Verify any customer settings. Then recalibrate the sensor.

¹ Lower numbers have higher priority

7 Ordering Information

7.1 Replacement Parts

See [Table 18](#) for replacement parts. For a full list of replacement sensors, see A-5K-SENS (currently not part of the manual). To obtain a replacement sensor, address the order or inquiry to:

Mine Safety Appliances Company
1000 Cranberry Woods Drive
Cranberry Township, PA 16066

or call, toll-free, 1-800-672-4678.

Inquiries can also be e-mailed to customer.service@msasafety.com.

WARNING!

Use only genuine MSA replacement parts when performing any maintenance procedures provided in this manual. Failure to do so may seriously impair sensor and gas monitoring performance, alter flameproof/explosionproof characteristics or void agency approvals. Failure to follow this warning could cause the product to fail to perform as designed and persons who rely on this product for their safety could sustain serious personal injury or loss of life.

Repair or alteration of the ULTIMA X5000 Gas Monitor, beyond the scope of the maintenance procedures provided in this manual or by anyone other than authorized MSA service personnel, could cause the product to fail to perform as designed and persons who rely on this product for their safety could sustain serious personal injury or loss of life.

Table 18 Replacement Parts and Accessories

Type	Description	Part Number
PCBA Assemblies		Refer to A-X5000-PCB
Sensor Body		Refer to A-5K-SENS
Sensors, All		Refer to A-5K-SENS
Sensor Guard, XCell	REPLACEMENT SENSOR GUARD FOR XCELL SENSORS	10184683
Sensor Guard, ULTIMA XIR PLUS	REPLACEMENT SENSOR GUARD FOR XIR PLUS SENSORS	10184684
Mounting Bracket Kit	MOUNTING BRACKET, ULTIMA X5000, KIT	10179361
Calibration Kit	CALIBRATION HARDWARE (CYLINDER NOT INCLUDED)	CALKIT1
JB5000 Junction Box	3/4" NPT CSA/ATEX/IEC Approved M25 CSA/ATEX/IEC Approved 3/4" NPT FM Approved M25 FM Approved	10213892 10213896 10213892 10213896
Calibration Cap, XCell	CALIBRATION CAP, ULTIMA X5000/S5000, PCKGD	10181450
Calibration Cap, XIR PLUS	CALIBRATION CAP, ULTIMA XIR PLUS, PCKGD	10181461
Duct Mount Kit	Rectangular Duct Mount Kit, ULTIMA X5000	10176947
	Round Duct Mount Kit, Small, ULTIMA X5000	10179124
	Round Duct Mount Kit, Large, ULTIMA X5000	10179321
Pipe Mount Kit, Universal	20-150 mm Pipe Mount, ULTIMA X5000/S5000	10176946
Pipe Mount Kit, 2" U-Bolt	2" Pipe Mount Kit, ULTIMA X5000	10179873
Sun Shield	Sunshield, ULTIMA X5000/S5000	10180254
SM5000	Sampling Module, DC Pump Model	10043264

Type	Description	Part Number
SM5000	Sampling Module, Aspirated Pump	10058101
SM5000	Flow Block Digital	10041866
SM5000	Flow Block XIR	10042600
XIR Plus	Insect guard	10225320
X5000	Short lid assembly	10187124
X5000	Deep lid assembly	10187125
12 AWG Wire Adapter	12 AWG (4mm ²) Power Terminal Adapter	10178512

For position of labels, see [2.11 Label Overview](#).

8 Appendix: Specifications

Table 19 Specifications

Sensor Options										
	CO	H ₂ S	SO ₂	CL ₂	NO ₂	H ₂ S 500 PPM	Hydrogen 1000 PPM	NH ₃ - 100 PPM	NH ₃ - 1000 PPM	SO ₂ - 100 PPM
Operating Range ²	-40 °C to +60 °C	-40 °C to +60 °C	-40°C to +60°C	-40°C to +60°C	20°C to +50°C*	-20 °C to +40 °C	-20°C to +50°C*	-30 °C to +50 °C	-30 °C to +50 °C	-20 °C to +50 °C
Storage	-40 °C to +60 °C	-40 °C to +60 °C	-40°C to +60°C	-40°C to +60°C	-40°C to +50°C	-40°C to +50°C	-0°C to +20°C	-20°C to +40°C	-20°C to +40°C	-20°C to +40°C
Zero Drift ¹	< 1% FS per year	< 1% FS per year	≤ 1% FS per month	< 1% FS per month	< 1% FS per month	< 1% FS per month	< 1% FS per month	< 1% FS per month	< 1% FS per month	< 1% FS per month
Span Drift ¹	< 2% FS per year	< 2% FS per year	≤ 2% FS per month	≤ 2% FS per month	≤ 2% FS per month	≤ 2% FS per month	≤ 2% FS per month	≤ 2% FS per month	≤ 2% FS per month	≤ 2% FS per month
Noise ¹	< 2 display units	< 2 display units	< 2 display units	< 2 display units	< 2 display units	< 2 display units	< 2 display units	< 2 display units	< 2 display units	< 2 display units
Repeatability ¹	< ±2%	< ±1%	±1%	±1%	< ±10%	< ±10%	< ±10%	< 1%	< ±15%	< ±15%
Resolution	1 ppm	0.1 ppm	0.1 ppm	0.1 ppm	0.1 ppm	1 ppm	10 ppm	1 ppm	10 ppm	0.5 ppm
T90	< 9 s	< 23 s	< 6s	< 12s	< 60 s	< 60 s	<185 s	< 60 s	< 300 s	< 30 s
T50					< 30 s	< 20 s	< 40 s	< 20 s	< 20 s	< 10 s
Humidity	5-95%	5-95%	5-95%	5-95%	15-90%	15-90%	15-90%	15-90%	15-90%	15-90%
Expected Sensor Life	5 years	5 years	5 years	5 years	2 years in the air	2 years in the air	2 years in the air	5 years	2 years in the air	2 years in the air
Warranty	3 years	3 years	3 years	3 years	1 year	1 year	1 year	3 years	1 year	1 year
Enabling Technology	XCell - non- consuming	XCell - non- consuming	XCell - non- consuming	XCell - non- consuming	Electro- chemical	Electro- chemical	Electro-chemical	Electro- chemical	Electro- chemical	Electro- chemical
TruCal ³	Yes	Yes	No	No	No	No	No	No	No	No
SafeSwap	Yes	Yes	Yes	Yes	Yes	Yes	Yes	Yes	Yes	Yes
Remote Mount Distance	100 m	100 m	100 m	100 m	100 m	100 m	100 m	100 m	100 m	100 m

Sensor Options	CO	H ₂ S	SO ₂	CL ₂	NO ₂	H ₂ S 500 PPM	Hydrogen 1000 PPM	NH ₃ - 100 PPM	NH ₃ - 1000 PPM	SO ₂ - 100 PPM
	Power: Single Sensor	2.8 W	2.8 W	2.8 W	2.8 W	2.8 W	2.8 W	2.8 W	2.8 W	2.8 W
Power: Dual Sensing	3.6 W	3.6 W	3.6 W	3.6 W	3.6 W	3.6 W	3.6 W	3.6 W	3.6 W	3.6 W
*Extended Range				None	-40°C to +50°C	None	-40°C to +60°C	None		-40°C to +60°C

Sensor Options	Oxygen	Low Oxygen	Combustible Catalytic	XIR PLUS Combustibles	XIR PLUS Carbon Dioxide
Operating Range ²	-40 °C to +60 °C	-20 °C to +50 °C	-40°C to +60°C	-40°C to +60°C	-40°C to +60°C
Storage	-40 °C to +60 °C	-20 °C to +40 °C	-40°C to +60°C	-40°C to +60°C	-40°C to +60°C
Zero Drift ¹	0.2% Vol per year	< 1% FS per month	< 5% LEL per year	< 2% LEL per year	< 2% FS per year
Span Drift ¹	0.2% Vol per year	< 2% FS per month	< 5% LEL per year	Not Applicable	Not Applicable
Noise ¹	< 2 display units	< 2 display units	1% LEL	1% LEL	0.05%
Repeatability ¹	< ±1%	< ±10%	±1%	±1%	±1%
Resolution	01% Vol	0.10%	1% LEL	1% LEL	<0.05%
T90	< 11 s	< 30 s	< 22 s	< 2 s	< 6 s
Humidity	10-95%	10-90%	5-95%	5-95%	5-95%
Expected Sensor Life	5 years	2 years in air	5 years	10 years	10 years
Warranty	3 years	1 years	3 years	electronics: 5 years IR source bulb: 10 years	
Enabling Technology	XCell - non-consuming	Lead based	XCell - GM cat bead	XIR PLUS	XIR PLUS
TruCal ³	No	No	No	No	No
SafeSwap	Yes	Yes	Yes	No	No
Remote Mount Distance	100 m	100 m	100 m	100 m	100 m
Power: Single Sensor	2.8 W	2.8 W	4.9 W	6.7 W	6.7 W
Power: Dual Sensing	3.6 W	3.6 W	10.6 W	11.6 W	11.6 W
*Extended Range		-30 °C to +50 °C			

Sensor Options	HCL	NO	HCN	ETO	HF	CL02
	Operating Range ²	-20 °C to +40 °C	-30 °C to +40 °C	-20 °C to +40 °C	-20 °C to +40 °C	0°C to +50°C*
Storage	-30 °C to +40 °C	-20 °C to +40 °C	-20 °C to +40 °C	-20 °C to +40 °C	0°C to +50°C*	-40°C to +60°C
Zero Drift ¹	< 1% FS per month	< 1% FS per month	< 1% FS per month	< 1% FS per month	< 1% FS per month	< 1% FS per month
Span Drift ¹	< 2% FS per month	< 2% FS per month	< 2% FS per month	< 2% FS per month	< 2% FS per month	< 2% FS per month
Noise ¹	< 2 display units	< 2 display units	< 2 display units	< 2 display units	< 2 display units	< 2 display units
Repeatability ¹	< ±35%	< ±15%	< ±15%	< ±15%	< ±15%	< ±15%
Resolution	1 ppm	0.5 ppm	1 ppm	0.1 ppm	0.1 ppm	0.01 ppm
T90	< 120 s	< 20 s	< 70 s	< 140s	< 90 s	< 30 s
T50	< 30 s	< 5 s	< 30 s	< 50 s	< 60 s	<12s
Humidity	5 - 50%*	15 - 90%	15 - 90%	15 - 90%	15 - 60%	10 - 95%
Expected Sensor Life	2 years	2 years	2 years	2 years	2 years	5 years
Warranty	1 year	1 year	1 year	1 year	1 year	3 years
Enabling Technology	Electrochemical	Electrochemical	Electrochemical	Electrochemical	Electrochemical	XCell
TruCal ³	No	No	No	No	No	No
SafeSwap	Yes	Yes	Yes	Yes	Yes	Yes
Remote Mount Distance	100 m	100 m	100 m	100 m	100 m	100 m
Power Single Sensor	2.8 W	2.8 W	2.8 W	2.8 W	2.8 W	2.8 W
Power Dual Sensor	3.6 W	3.6 W	3.6 W	3.6 W	3.6 W	3.6 W
Extended Range	-30 C to 40 C	-30 C to 50 C	-30 C to 50 C		-10 C to 50 C	-40 C to 60 C

¹ Typical response at room temperature

² X5000 transmitter has an operating temperature range of -40°C to +60°C

³ Adaptive Environmental Compensation (AEC) and Diffusion Supervision (DS) will remain active between -20°C and +60°C.

9 Appendix: Calibration Guide for Additional Gases

The ULTIMA XIR PLUS sensor can be calibrated for a wide variety of combustible gas compounds.



This information is only applicable for combustible XIR PLUS sensors and does not apply to CO₂ and acetylene sensors.



The XIR PLUS sensor is only performance approved for Methane and Propane.

To change the XIR PLUS calibration,

1. Scroll and select Settings.
2. Select Sensor.
3. Scroll and select Gas Table.
4. Select the gas table for the target compound.
5. Select Save.
6. Scroll to Span Value and select (should already be in correct menu after saving Gas Table).
7. Enter the span value for the target compound as described in [Table 20](#) .
8. Select Save.
9. Go to the home screen.
10. Run a full calibration (Span and zero) using the calibration gas indicated in [Table 20](#) .

You can now calibrate the XIR PLUS sensor using the calibration gas for the target compound in [Table 20](#) .

WARNING!

- You must calibrate the XIR PLUS sensor with the calibration gas indicated in [Table 20](#) for the sensor to be accurate for the target gas.
- Curve 8 gas calibrations may require a special IR sensor for optimum performance. The standard Propane calibrated IR sensor may not perform properly if used outdoors with a Curve 8 calibration.

Failure to follow this warning can result in serious personal injury or death.

Table 20 XIR PLUS Calibration Guide for Additional Gases

Compound	Vol % for NA LEL	Vol % for EN LEL	Linearity Curve/Table	Cal Gas	NA Span Value	EN Span Value
Acetaldehyde	4.0	4.0	8	0.1 % Propane	29%	29%
Acetic Acid	4.0	4.0	3	0.6 % Propane	12%	12%
Acetone	2.5	2.5	8	0.1 % Propane	20%	20%
Acrolein	2.8	2.8	8	0.1 % Propane	59%	59%
Acrylic Acid	2.4	2.4	2	0.6 % Propane	10%	10%
Allyl Alcohol	2.5	2.5	1	2.5 % Methane	85%	85%
Allylamine	2.2	2.2	8	0.1 % Propane	18%	18%
Amyl Acetate	1.1	1.0	1	2.5 % Methane	80%	88%
t-Amyl Alcohol	1.3	1.4	6	0.6 % Propane	41%	38%
Aromatic 100	0.9	N/A	1	2.5 % Methane	75%	N/A
Benzene	1.2	1.2	8	0.1 % Propane	42%	42%
1,3-Butadiene	2.0	1.4	8	0.1 % Propane	23%	33%
Butane	1.9	1.4	4	0.6 % Propane	29%	39%
Butanol	1.4	1.4	6	0.6 % Propane	42%	42%
Butene	1.6	1.6	6	0.6 % Propane	57%	57%
Butyl Acetate	1.7	1.2	6	0.6 % Propane	40%	57%
Butyl Acrylate	1.5	1.2	6	0.6 % Propane	45%	56%
Butyl Methacrylate	2.0	1.0	6	0.6 % Propane	33%	66%
Butyraldehyde	1.4	1.7	6	0.6 % Propane	65%	54%
Cumene	0.9	0.8	1	2.5 % Methane	43%	48%
Cyclohexane	1.3	1.0	1	2.5 % Methane	50%	65%
Cyclohexanone	1.1	1.3	6	0.6 % Propane	74%	63%
Cyclopentane	1.5	1.4	7	0.6 % Propane	31%	33%
Cyclopentanone	1.5	1.6	1	2.5 % Methane	60%	56%
1,2-Dichloroethane	6.2	6.2	8	0.1 % Propane	14%	14%
Dicyclopentadiene (DCPD)	0.8	0.8	6	0.6 % Propane	55%	55%
Diethylamine	1.8	1.7	2	0.6 % Propane	32%	34%

Compound	Vol % for NA LEL	Vol % for EN LEL	Linearity Curve/Table	Cal Gas	NA Span Value	EN Span Value
Diethyl Ether	1.9	1.7	2	0.6 % Propane	38%	42%
Diethyl Ether	6.2	N/A	8	0.1 % Propane	20%	N/A
1,1-Difluoroethane (R-152a)	3.7	4.0	2	0.6 % Propane	52%	48%
Diisobutylene	0.8	0.8	2	0.6 % Propane	52%	52%
Diisopropyl Ether	1.4	1.0	6	0.6 % Propane	34%	48%
Dimethylamine	2.8	2.8	2	0.6 % Propane	37%	37%
Dimethylaminopropylamine (DMAPA)	2.3	1.2	2	0.6 % Propane	29%	56%
Dimethyl Ether	3.4	2.7	2	0.6 % Propane	32%	40%
Dimethylethylamine (DMEA)	2.3	N/A	2	0.6 % Propane	22%	N/A
Dimethylisopropylamine (DMIPA)	1.0	1.1	6	0.6 % Propane	47%	43%
1,4-Dioxane	2.0	N/A	4	0.6 % Propane	42%	N/A
1,3-Dioxolane	2.1	2.3	2	0.6 % Propane	35%	32%
Epichlorohydrin	3.8	2.3	6	0.6 % Propane	46%	76%
Ethane	3.0	2.4	3	0.6 % Propane	25%	31%
Ethanol	3.3	3.1	6	0.6 % Propane	35%	37%
Ethyl Acetate	2.0	2.0	6	0.6 % Propane	60%	60%
Ethyl Acrylate	1.4	1.4	8	0.1 % Propane	15%	15%
Ethyl Benzene	0.8	1.0	8	0.1 % Propane	15%	12%
Ethyl Chloride	3.6	3.6	2	0.6 % Propane	27%	27%
Ethylene	2.7	2.3	8	1.35 % Ethylene	50%	59%
Ethylene Diamine	4.2	2.5	8	0.1 % Propane	17%	29%
Ethylene Glycol Monomethyl Ether	1.8	1.8	6	0.6 % Propane	60%	60%
Ethylene Oxide	3.0	2.6	6	0.6 % Propane	65%	75%
Gasoline (as Hexane)	1.1	1.0	6	0.6% Propane	41%	45%
Heptane	1.1	0.85	2	0.6% Propane	35%	45%
Hexamethyldisiloxane (HMDS)	0.5	0.5	8	0.1% Propane	22%	22%
Hexane	1.1	1.0	6	0.6% Propane	41%	45%

Compound	Vol % for NA LEL	Vol % for EN LEL	Linearity Curve/Table	Cal Gas	NA Span Value	EN Span Value
1-Hexene	1.2	1.2	6	0.6% Propane	38%	38%
Isobutane	1.8	1.3	2	0.6% Propane	30%	42%
Isobutyl Alcohol	1.7	1.4	6	0.6% Propane	41%	50%
Isobutyl Isobutyrate (IBIB)	1.0	0.8	1	2.5% Methane	25%	31%
Isobutylene	1.8	1.6	6	0.6% Propane	62%	70%
Isooctane	1.1	0.7	4	0.6% Propane	28%	44%
Isopropanol	2.0	2.0	6	0.6% Propane	48%	48%
Isopropyl Acetate	1.8	1.7	6	0.6% Propane	57%	60%
Isopropyl Amine	2.0	2.3	6	0.6% Propane	41%	36%
JP-5	0.6	N/A	6	0.6% Propane	41%	N/A
Methanol	6.0	6.0	3	0.6% Propane	23%	23%
Methoxypropylamine	2.3	2.3	6	0.6% Propane	55%	55%
Methyl Acetate	3.1	3.1	5	0.6% Propane	46%	46%
Methyl Acrylate	2.8	1.95	6	0.6% Propane	68%	N/A
Methacrylic Acid	1.6	2.1	2	0.6% Propane	55%	42%
Methyl Amyl Ketone (MAK)	1.1	1.1	6	0.6% Propane	51%	51%
Methyl Cellosolve	1.8	1.8	6	0.6% Propane	60%	60%
Methyl Chloride	8.1	7.6	6	0.6% Propane	48%	51%
Methyl Chloroform (1,1,1-Trichloromethane)	0.1	N/A	6	0.6% Propane	85%	N/A
Methylcyclohexane	1.2	1.0	1	2.5% Methane	33%	40%
Methylene Chloride	13.0	13.0	1	2.5% Methane	68%	68%
Methylene Fluoride (R-32)	12.7	12.7	6	0.6% Propane	13%	13%
Methyl Ethyl Ketone (MEK)	1.4	1.5	1	2.5% Methane	72%	67%
Methyl Formate	4.5	5.0	4	0.6% Propane	29%	26%
Methyl Isobutyl Carbinol (MIBC)	1.0	1.14	2	0.6% Propane	25%	22%
Methyl Isobutyl Ketone (MIBK)	1.2	1.2	6	0.6% Propane	54%	54%
Methyl Mercaptan	3.9	4.1	8	0.1% Propane	17%	16%

9 Appendix: Calibration Guide for Additional Gases

Compound	Vol % for NA LEL	Vol % for EN LEL	Linearity Curve/Table	Cal Gas	NA Span Value	EN Span Value
Methyl Methacrylate	1.7	1.7	6	0.6% Propane	72%	72%
Methyl Propyl Ketone (MPK)	1.5	1.5	6	0.6% Propane	54%	54%
Methyl tert-butyl Ether (MTBE)	1.6	1.5	2	0.6% Propane	29%	31%
Monomethyl Amine	4.9	4.2	2	0.6% Propane	33%	39%
Morpholine	1.4	1.4	6	0.6% Propane	59%	59%
Naptha, VM&P	1.2	N/A	6	0.6% Propane	41%	N/A
Nitro Methane	7.3	7.3	8	0.1% Propane	45%	45%
Nitro Ethane	3.4	3.4	1	2.5% Methane	85%	85%
Opteon XL 41 (R-454b)	11.3	N/A	3	0.6% Propane	20%	N/A
Pentane	1.5	1.1	5	0.6% Propane	33%	45%
n-Propanol	2.2	2.1	2	0.6% Propane	36%	38%
Propionaldehyde (Propanal)	2.6	2.0	6	0.6% Propane	69%	n.a.
Propyl Acetate	1.7	1.7	6	0.6% Propane	41%	41%
Propyl Bromide	3.8	3.4	2	0.6% Propane	23%	26%
Propyleneimine	1.32	N/A	6	0.6% Propane	72%	N/A
Propylene Glycol Methyl Ether (PGME)	1.8	1.6	6	0.6% Propane	47%	53%
Prop. Glycol Meth. Ether Acetate (PGMA)	1.5	1.3	6	0.6% Propane	67%	77%
Propylene Oxide	2.3	1.9	2	0.6% Propane	38%	46%
Pyridine	1.8	1.7	8	0.1% Propane	20%	21%
Stoddard Solvent	0.9	N/A	2	0.6% Propane	32%	N/A
Styrene	0.9	1.0	8	0.1% Propane	45%	41%
Tetrahydrofuran (THF)	2.0	1.5	2	0.6% Propane	40%	53%
Tetrahydropyran (THP)	1.6	N/A	6	0.6% Propane	40%	N/A
tert-Butanol	2.4	1.4	2	0.6% Propane	27%	46%
Toluene	1.1	1.0	8	0.1% Propane	18%	20%
1,1,1-Trichloroethane	7.5	9.5	8	0.1% Propane	20%	16%
Tetrahyrdothiophene (THT)	1.5	1.5	1	2.5% Methane	29%	29%

Compound	Vol % for NA LEL	Vol % for EN LEL	Linearity Curve/Table	Cal Gas	NA Span Value	EN Span Value
Triethylamine	1.2	1.2	6	0.6% Propane	36%	36%
Trimethylamine	2.0	2.0	2	0.6% Propane	38%	38%
Turpentine	0.8	0.8	8	0.1% Propane	20%	20%
Vinyl Acetate	2.6	2.6	8	0.1% Propane	63%	63%
Vinyl Trimethoxysilane	1.1	N/A	2	0.6% Propane	35%	N/A
Xylenes (O-Xylene)	0.9	0.9	1	2.5% Methane	59%	59%

10 Appendix: General Certification Information

Refer to manual addendum (P/N 10182779) for additional Certification Information.

⚠ WARNING!

Some toxic gases are provided in a fritless sensor housing. The fritless sensor housing is labeled as Div 2 or Zone 2 and is approved for Div 2 or Zone 2 installations only. The protection method is Nonincendive or Type n respectively. Ensure all components are approved for the wiring method being used and in accordance with the National Electrical Code of the country of use, any applicable local regulations, this manual and the addendum to the manual. Failure to follow this warning can result in serious injury or loss of life.

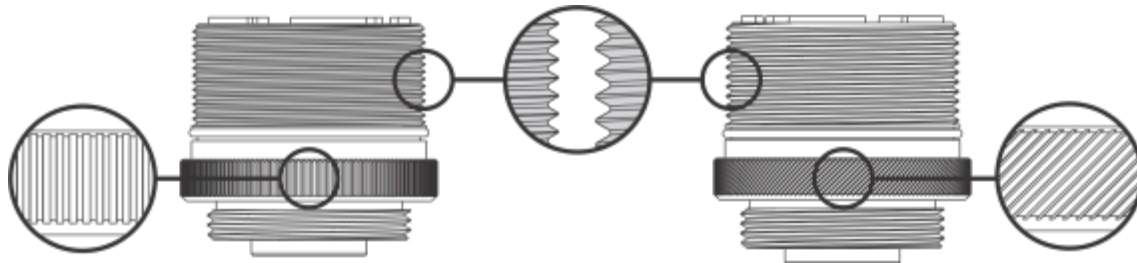

Figure 45 Digital Sensor for Div 1 & 2, Zone 1 & 2 (Left) vs Digital Sensor for Div 2, Zone 2 only (right)

FM APPROVAL

This Approval does not include or imply Approval of apparatus to which the subject instrument may be connected. In order to maintain an FM Approved system, the apparatus to which this instrument is connected, must also be Approved by FM Approvals. As part of this Approval, it was verified that optional communication functions of this gas detection instrument while operating at the maximum transaction rate do not adversely affect the gas detection operation and functions of the instrument. This Approval, however, does not include or imply Approval of the communications protocol or functions provided by the software of this instrument or of the communications apparatus or software connected to this instrument.

The ULTIMA X5000 Transmitter, X5000 Junction Box, ULTIMA XIR PLUS and Digital Sensors (H₂S, 500 ppm H₂S, CO, O₂, Combustibles) also have FM Performance Approval for use in ordinary (non-hazardous) or hazardous locations.

The following information shall be noted for FM Approved configurations:

- The FM Approved Digital Sensors have an IP65 and TYPE 3X environmental rating, however if water is splashed onto the frit (also referred to as a flame arrestor), the sensor may not be able to detect gas for a period of up to 12 minutes. If water is splashed onto this element, use a cloth or paper towel to dab the frit in order to absorb any excess water.
- The FM Approval requires that password protection for Bluetooth be enabled.
- The Digital Sensor (O₂) is not to be used in environments containing 5 % (v/v) or more of Carbon Dioxide.
- The Digital Sensor (O₂) is unaffected by air velocities of up to 5 m/s
- The response and recovery times for the Digital Sensor (H₂S, 500 ppm H₂S, CO, O₂) are as follows:

Specification	Digital Sensor		
	H ₂ S	H ₂ S 500 ppm	CO
T20	5 sec	4 sec	4 sec
T50	7 sec	6 sec	6 sec
T90	18 sec	30 sec	15 sec
T10 (recovery)	67 sec	35 sec	54 sec

Specification	Digital Sensor (O ₂)
T lowest alarm setpoint	5 sec
T highest alarm setpoint	5 sec

Table 21 Operating and Storage Temperature Range

	Storage Temperature Range		Operating Temperature Range		Pressure Limits
	min °C	max °C	min °C	max °C	
X5000 Transmitter	-40	+60	-40	+60	86 kPa - 108 kPa
Junction Box	-50	+85	-40	+60	86 kPa - 108 kPa
Digital Sensor (H₂S, CO)	-40	+60	-40	+60	86 kPa - 108 kPa
Digital Sensor (H₂S, 500 ppm)	-40	+60	-40	+50	86 kPa - 108 kPa
Digital Sensor (O₂)	-40	+60	-40	+60	86 kPa - 108 kPa

Table 22 Accuracy Spec

	Accuracy
Digital Sensor (H ₂ S)	±3 ppm or 10% of reading
Digital Sensor (H ₂ S, 500 ppm)	±3 ppm or 10% of reading (-20°C to +40°C) -20% of reading (-20°C to -40°C) +25% of reading (+40°C to +50°C)
Digital Sensor (CO)	±6 ppm or ±10% of reading (-10°C to +60°C) +15% of reading (-10°C to -20°C) -30% of reading (-20°C to -40°C)

	Accuracy
Digital Sensor (O ₂)	±0.5% O ₂ (FM 6340) ±0,2 % (v/v) or ± 2,5 % of the measuring range (EN 50104)

11 Appendix: HART Specific Information

The ULTIMA X5000 Gas Monitor is available with an optional HART (Highway Addressable Remote Transducer) output communications protocol. With this option, the ULTIMA X5000 complies with HART Protocol Revision 7.

All available status bytes are defined in the X5000 HART Specification found on the product CD. Refer to that document for complete HART command and status definitions. Use the HART digital interface to query the unit to provide additional troubleshooting information.

Table 23 Device Identification

Manufacturer Name	Mine Safety Appliances, Inc (MSA)	Model Name	ULTIMA X5000
HART ID Code	227 (0xE3)	Device Type Code	46 (0x2E)
HART Protocol -Revision	7	Device Revision	1
Number of Device Variables	2		
Physical Layers Supported	FSK		

12 Appendix: Modbus RTU Protocol Operation

Connection to X5000 transmitter:

- The 2-Wire RS485 connection terminal is shown to the left of the HART connection

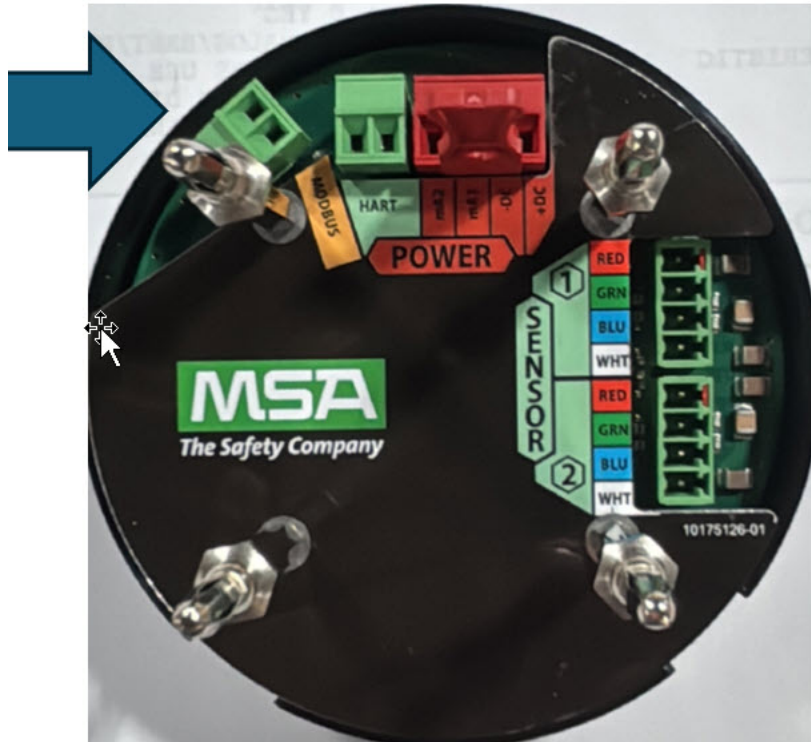

- Connection wire must be Low Capacitance, Shielded data cable, 100-120 Ohm impedance. 1000 feet or 300 meters maximum distance.

12.1 Baud Rate

The baud rate is selectable via the Modbus Communications Interface. The selectable baud rates are as follows:

Table 24 Baud Rate

User Select	Baud Rates
0	2400 bits per second

User Select	Baud Rates
1	4800 bits per second
2	9600 bits per second
3	19200 bits per second
4	38400 bits per second
5	115200 bits per second

12.2 Data Format

The data format is selectable via the Modbus Communications Interface. The selectable data formats are as follows:

Table 25 Data Format

User Select	Data Bits	Parity	Stop Bit	Format
0	8	None	1	8-N-1
1	8	Even	1	8-E-1
2	8	Odd	1	8-O-1
3	8	None	2	8-N-2

Consult Modbus Manual (PN: MANS5000M) for Modbus RTU protocol configuration.

Table 26 Housing Specifications

Transmitter Weight:	Short Lid: 6.5 lb.
	Deep Lid: 8.8 lb.
Material Spec:	AISI 316 Stainless Steel

Transmitter Dimensions

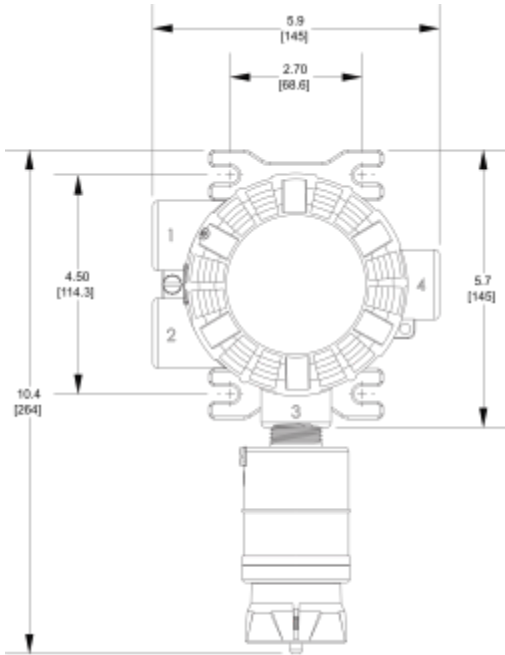

Figure 46 ULTIMA X5000 Height & Width

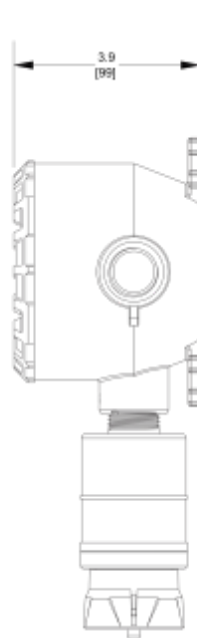

Figure 47 Short Lid Depth

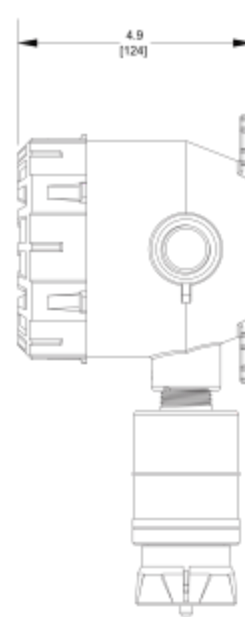

Figure 48 Deep Lid Depth

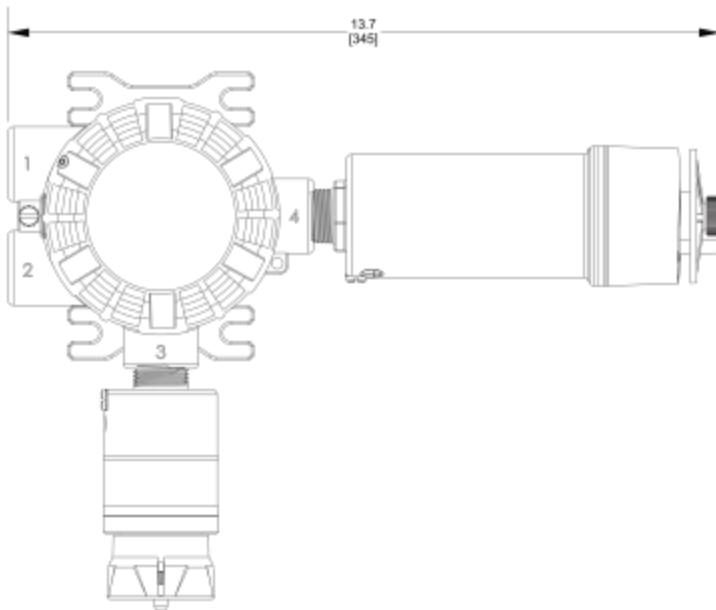

Figure 49 ULTIMA X5000 Width with XIR PLUS Sensor

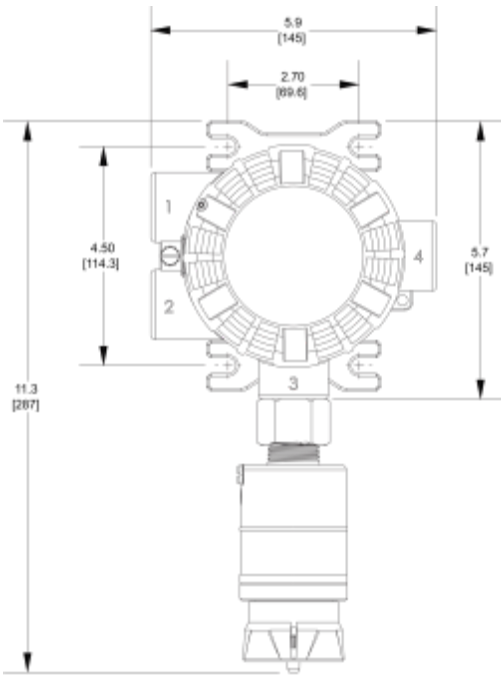

Figure 50 ULTIMA X5000 Height & Width with M25 Adapter

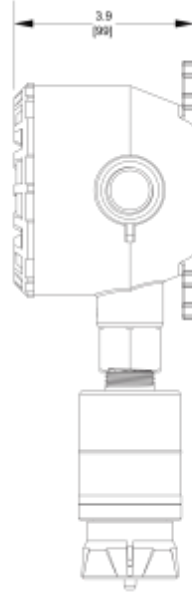

Figure 51 Short Lid Depth with M25 Adapter

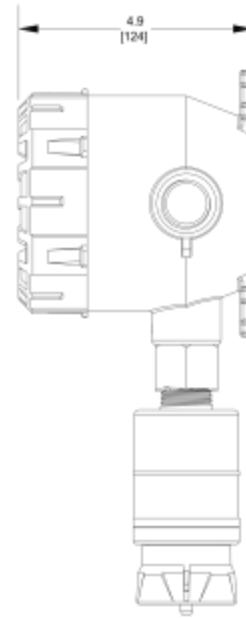

Figure 52 Deep Lid Depth with M25 Adapter

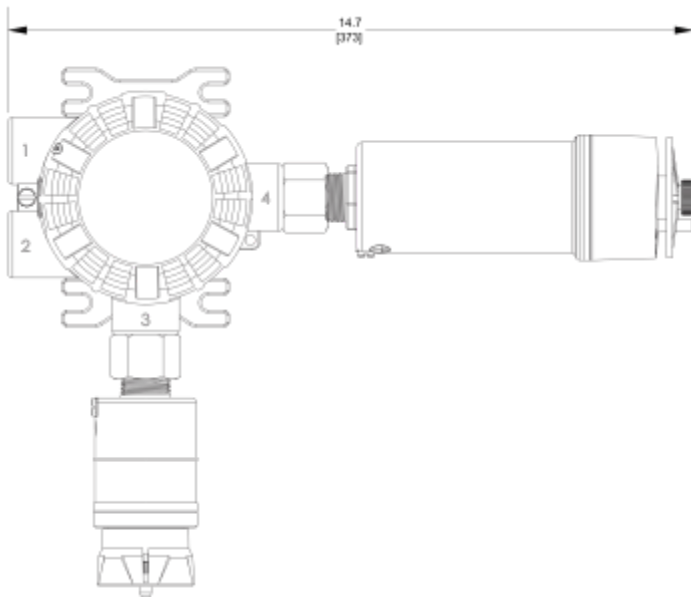
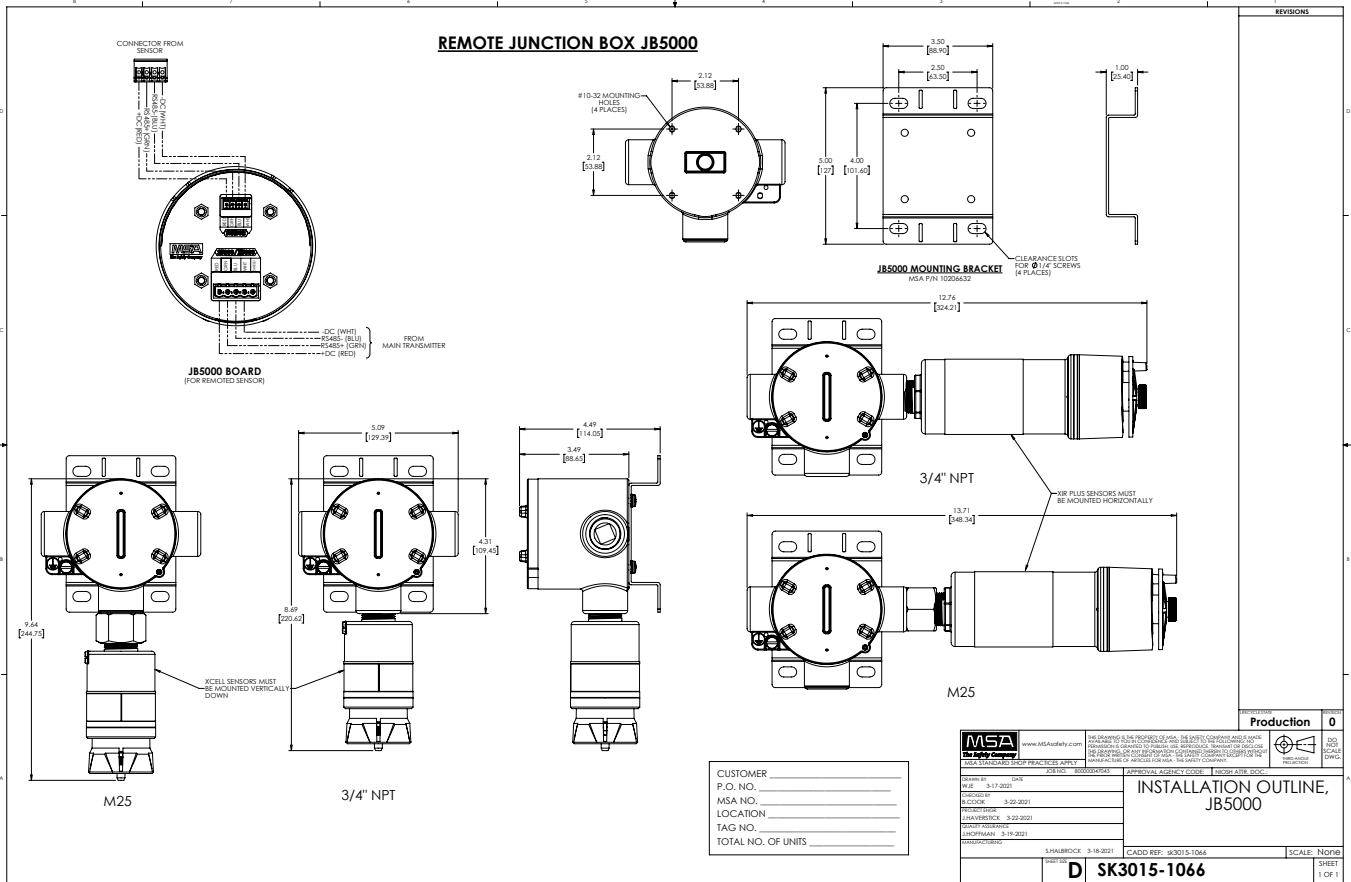

Figure 53 ULTIMA X5000 Width with XIR PLUS Sensor with M25 Adapter

Figure 54



CUSTOMER _____
P.O. NO. _____
MSA NO. _____
LOCATION _____
TAG NO. _____
TOTAL NO. OF UNITS _____

MSA www.MSAafety.com	REVISIONS	APPROVALS	DATE
DESIGNED BY: GSK	1	DESIGNED BY: GSK	3-11-2011
DRAWN BY: GSK	2	DRAWN BY: GSK	3-22-2011
CHECKED BY: GSK	3	CHECKED BY: GSK	3-22-2011
DATE: 3-11-2011	4	DATE: 3-11-2011	

INSTALLATION OUTLINE, JB5000

Production 0

SCALE: None
SHEET 1 OF 1

D SK3015-1066

